

Gliederung

1. Einführung
2. Anforderungen an Bremssysteme im SPNV
3. Bremskraftherzeugung

Was gehört zu einem Bremssystem?

Bremssystem

Überwachung und Diagnose



Bedienelement(e)



Bremssteuerung



Energieversorgung
und Bremskraftregelung



Bremskraftherzeugung

Bedienelemente, Bsp. 1 (DVB)



Bedienelemente, Bsp. 1 (DVB)



Bedienelemente, Bsp. 2



Bedienelemente, Bsp. 2 (Saarbahn)



Fahrzeuge des SPNV - Bremsen

Bremsbauarten SPNV

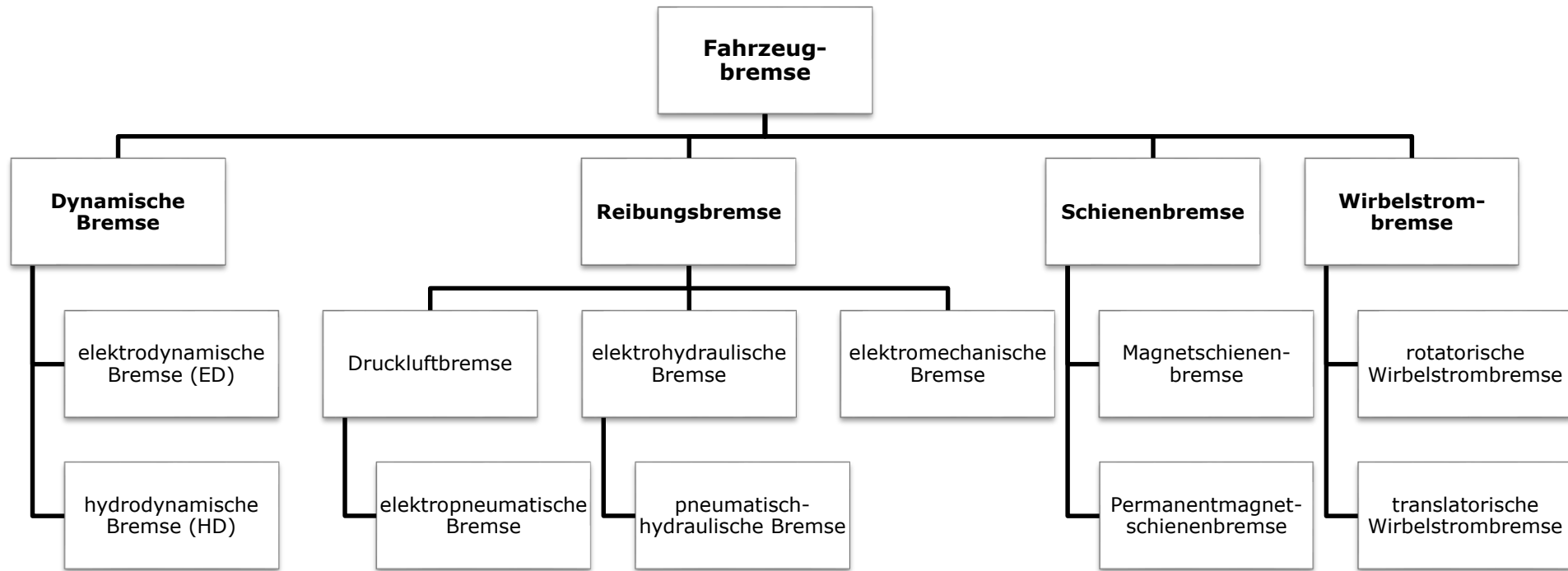

geläufige Bremsausrüstungen:







- elektrodynamische Bremse
- **elektropneumatische Bremse**
- pneumatische Bremse
- **elektrohydraulische Bremse**
- Magnetschienenbremse
- **elektromechanische Bremse**

im Versuchsbetrieb:

rotatorische Wirbelstrombremse

Welche Bremssysteme werden auf welchen Fahrzeugen eingesetzt?

Legende:
X - Standard
 (X) - fallweise

		Druckluft- bremse	Direkte ep-Bremse	elektrohydr. Bremse	dynamische Bremse	Schienen- bremse	Federspeicher- bremse
 Straßen- bahnen				X	X	X	X
 Stadt- bahnen			(X)	X	X	X	X
 Unter- grund- bahnen			X		X	(X)	X
 lokbsp. Züge		X			(X)	X	X
 S-Bahn- Züge		(X)	X		X	(X)	X
 Regional- triebzug		(X)	X		X	X	X
 HGV- Züge		(X)	X		X	X	X

Elektro-Dynamische Bremsen

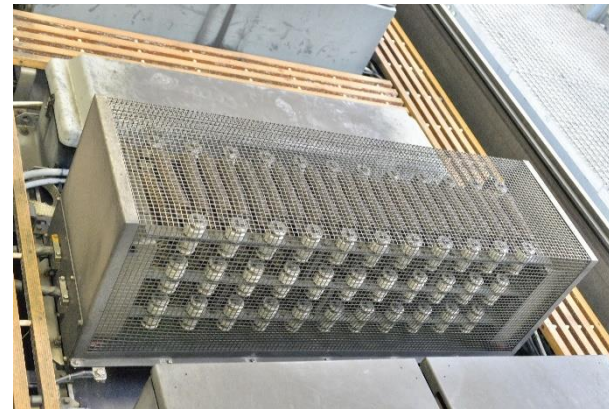
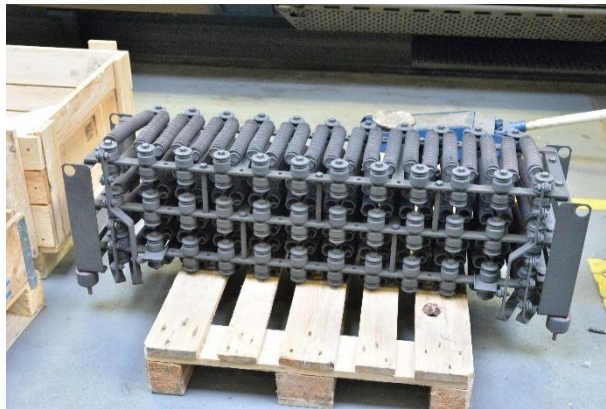

Blending ED - /mech. Bremse

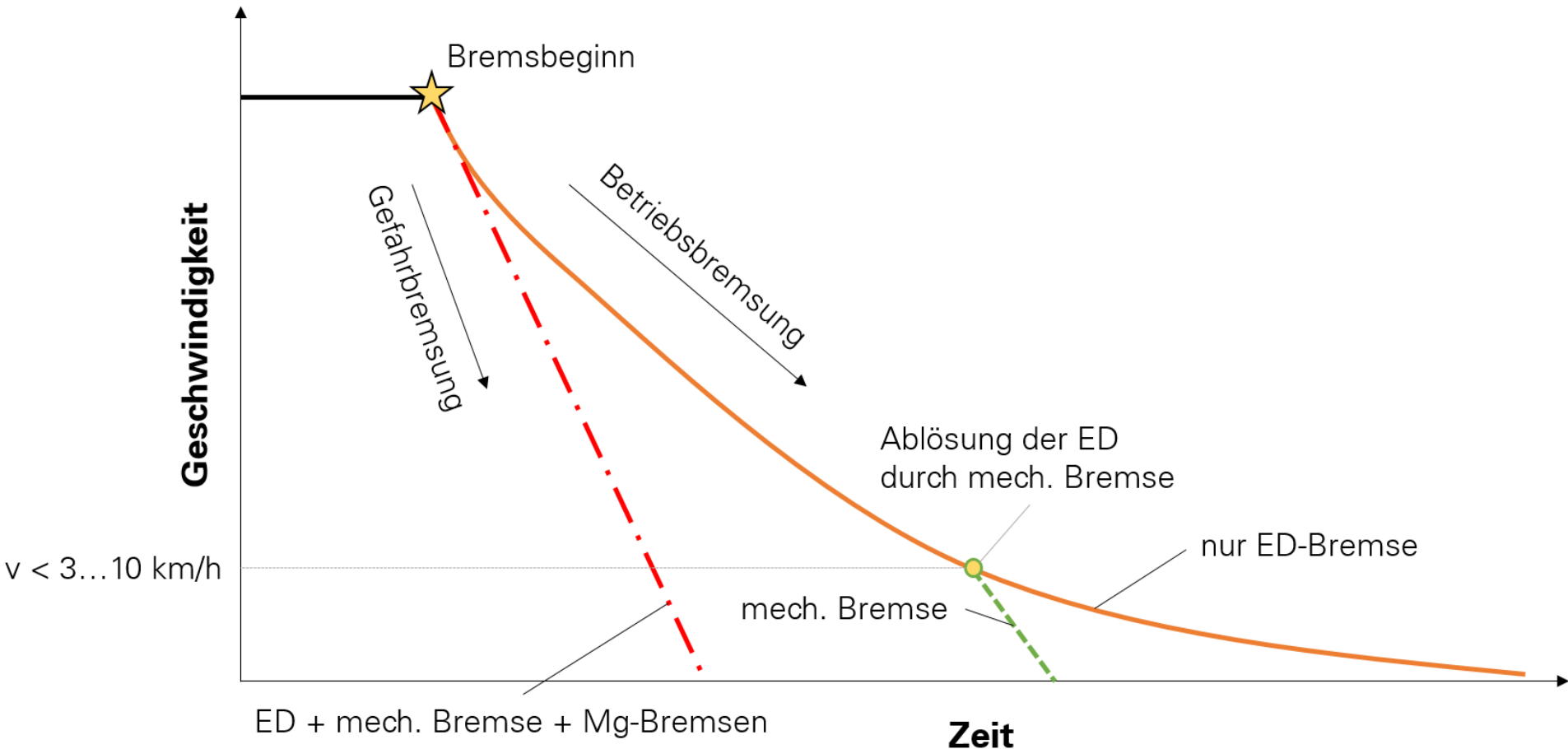

nach *Kipp* in: ZEV + DET Glas. Ann. 11/12 1995

Charakteristik ED-Bremse

Beispiel 1

NGT 6 der
MPK Krakow

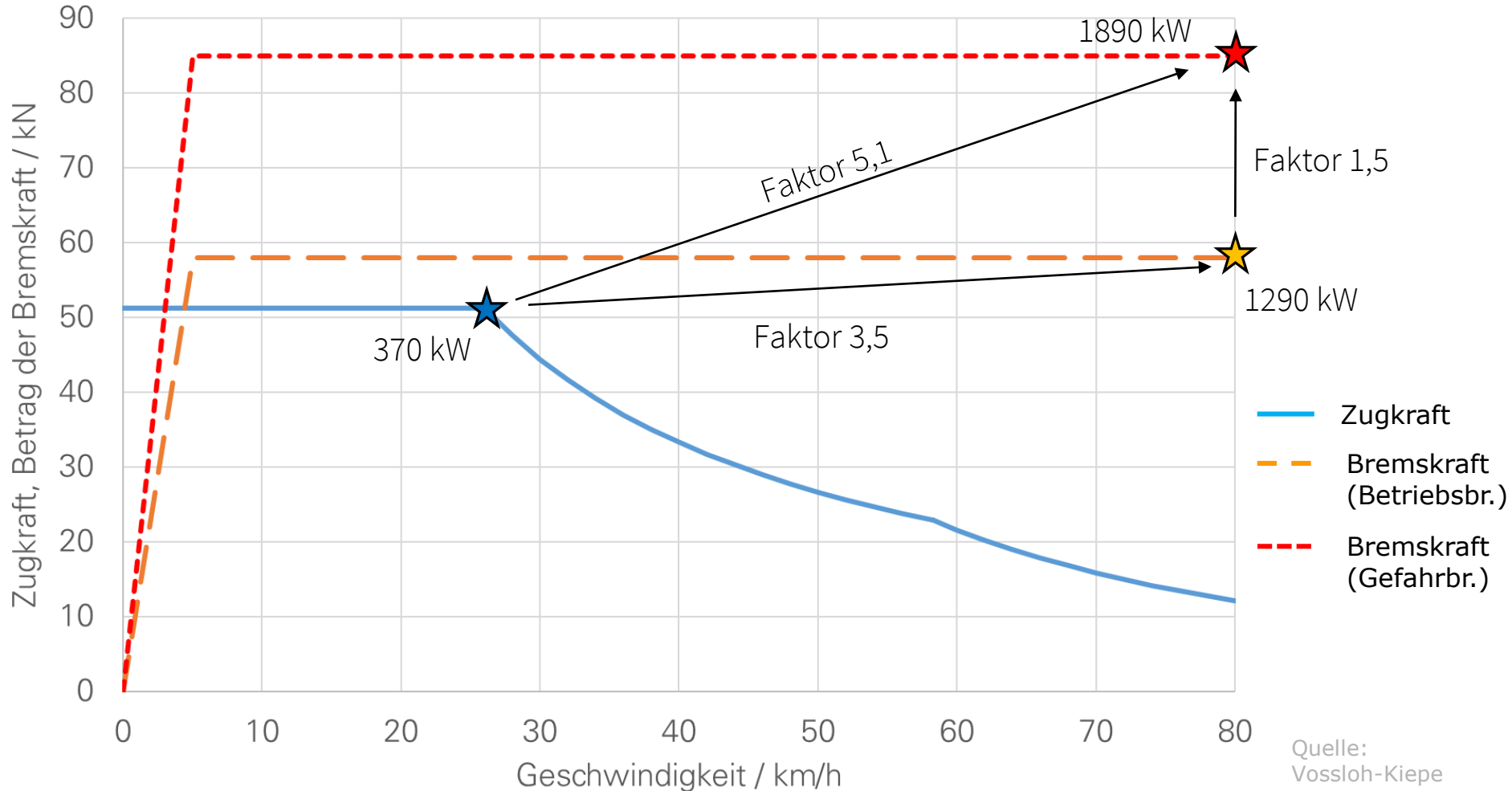

Quelle:
Vossloh-Kiepe

Charakteristik ED-Bremse

Beispiel 2

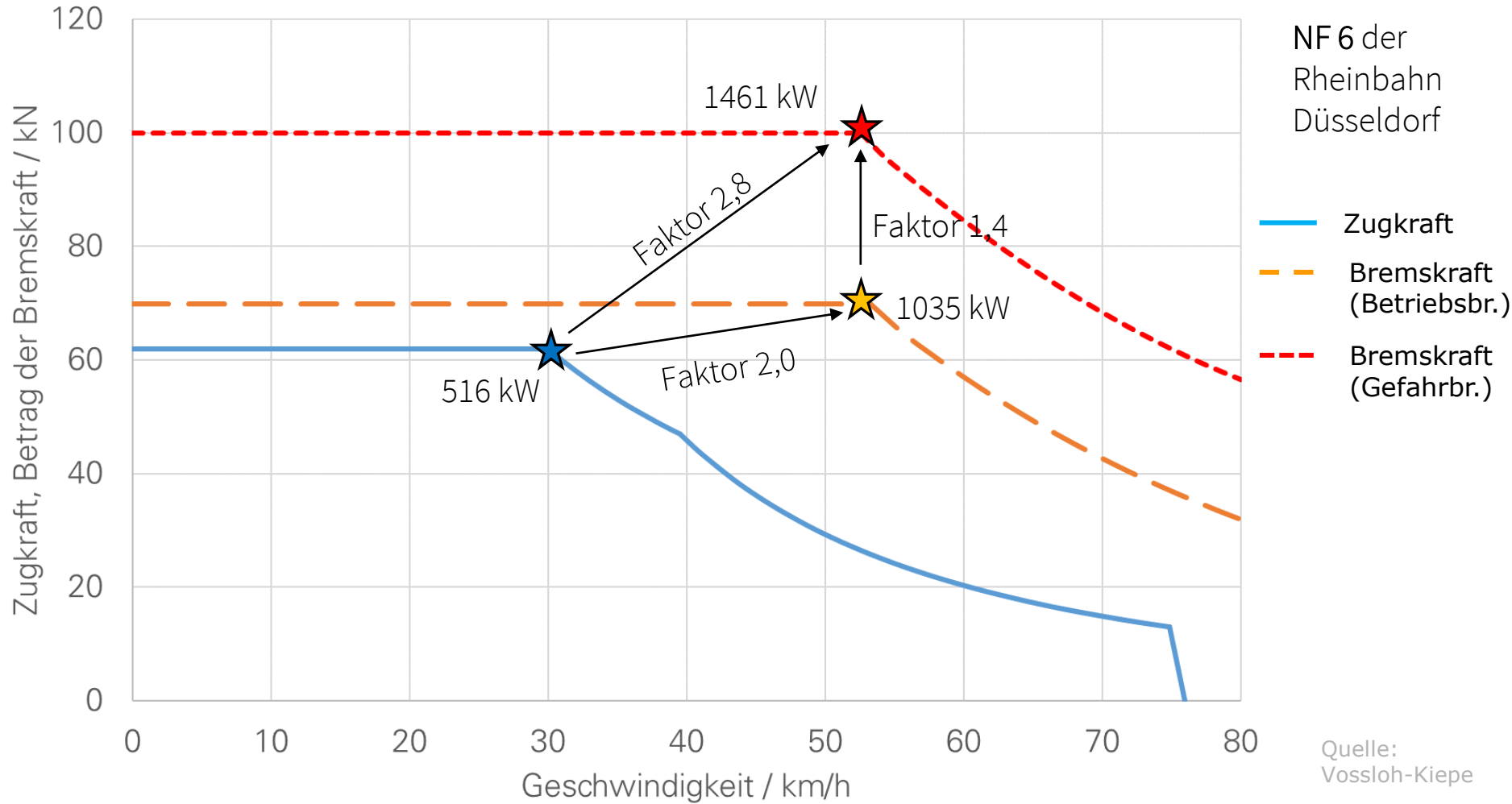

Bremse: Einbaumöglichkeiten Triebfahrwerke

Einzelradantrieb, außenliegend

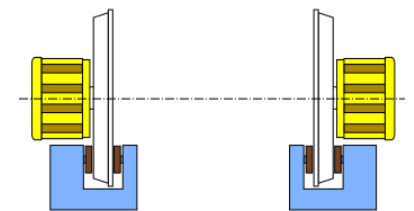
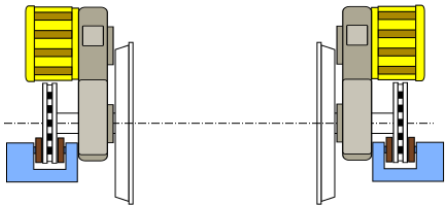
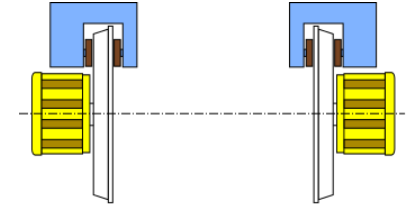
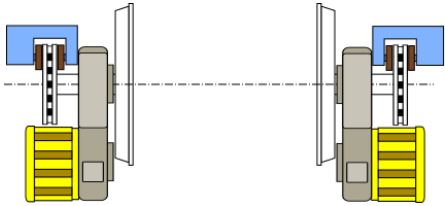

z.B. Eurotram



z.B. Adtranz/Stadler Variobahn



z.B. Škoda 15T



Bremse: Einbaumöglichkeiten Triebfahrwerke

außenliegende Längsantriebe 1

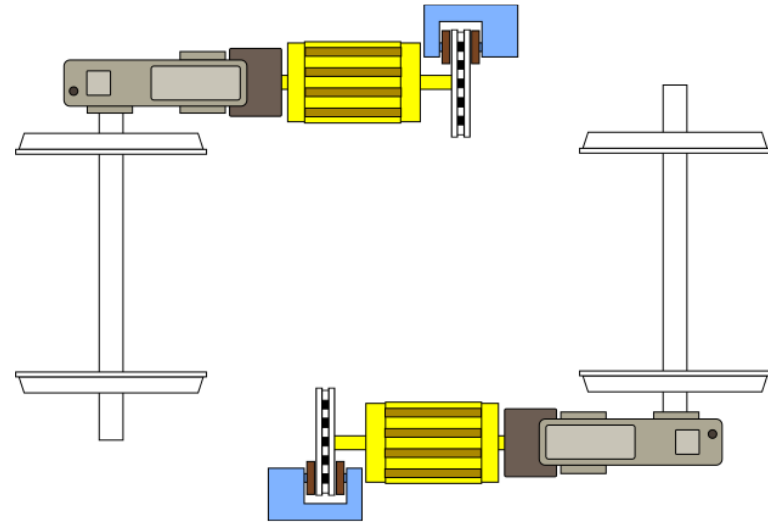

Beispiel:
Škoda 26T

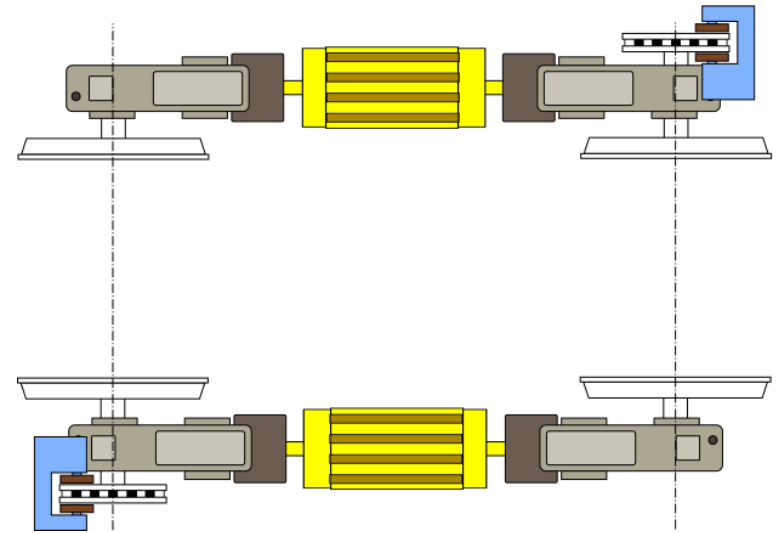

ALSTOM Citadis 302 C
(Corège-Fahrwerke)



Bremse: Einbaumöglichkeiten Triebfahrwerke

außenliegende Längsantriebe 2

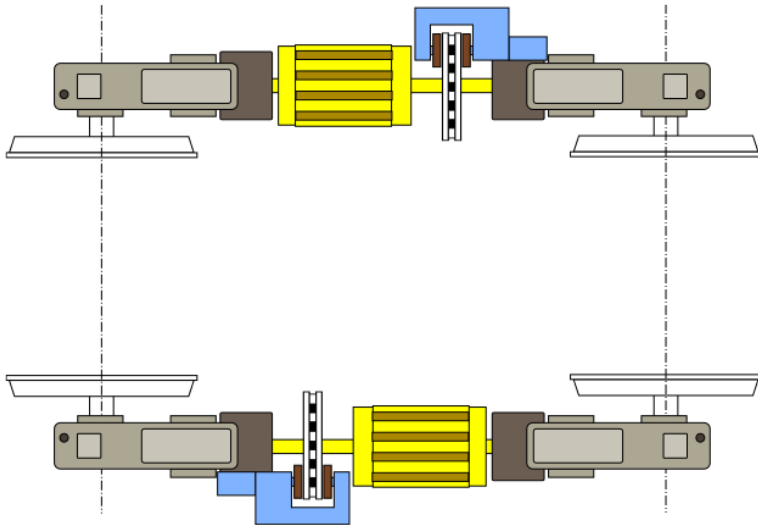

Beispiele:

Siemens Combino
Siemens Avenio

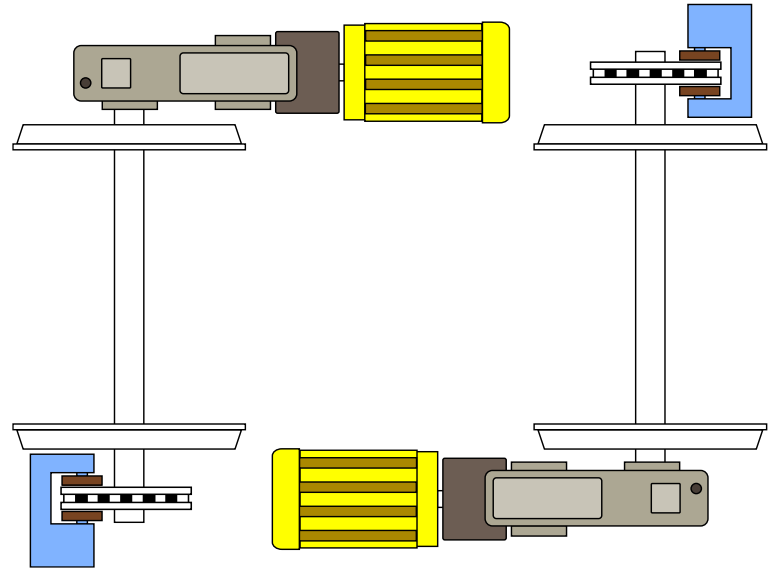

Beispiele:

ALSTOM Citadis X05 (Ixège-Fahrwerke)

Bombardier Flexity-2
(FLEXX-Urban-3000 - Fahrwerke)

Vossloh Tramlink

Caf Urbos

Transtech Artic Tram

Pesa Twist



Bremse: Einbaumöglichkeiten Triebfahrwerke innen liegende Querantriebe

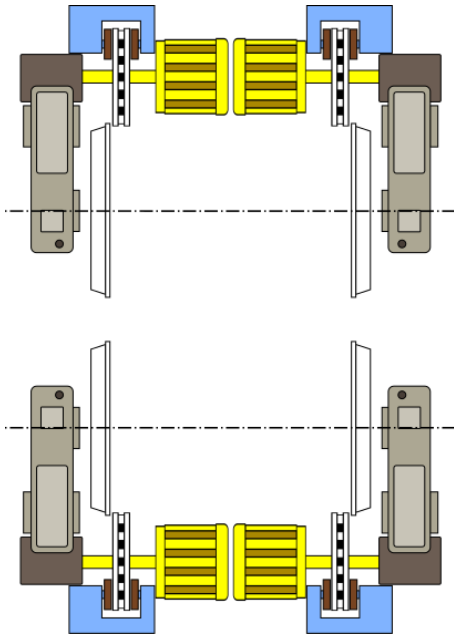

Beispiel:
DUEWAG MGT6D

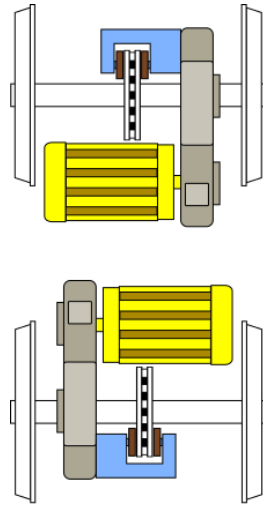

Beispiele:
ALSTOM Regio Citadis,
Bombardier Flexity Swift

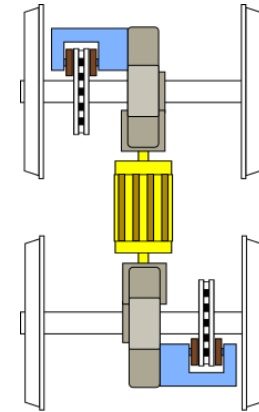

Beispiel:
Stadtbahnwagen, Typ M



Bremse: Einbaumöglichkeiten Triebfahrwerke

Antriebe mit gekoppelten Einzelrädern

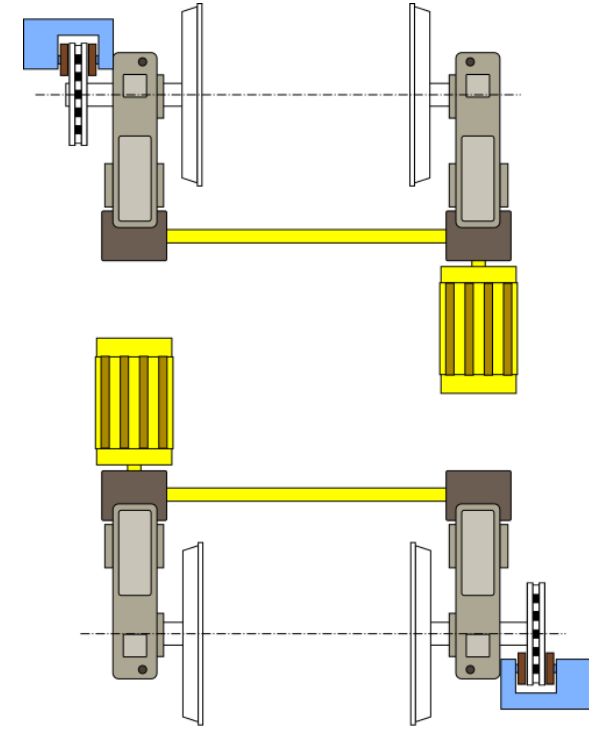
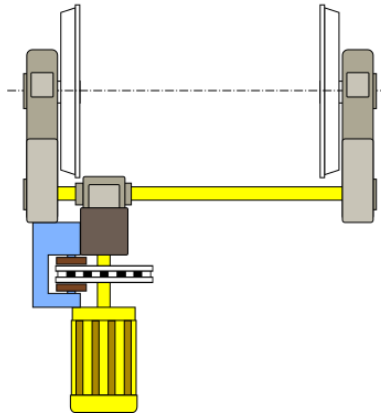
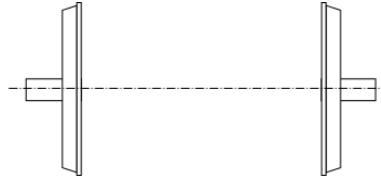
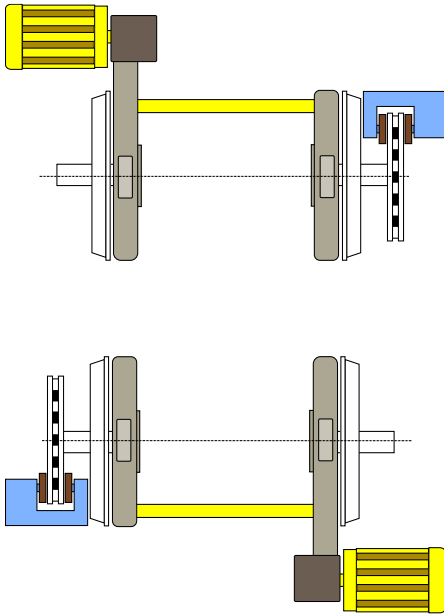

Beispiele:

Alstom Citadis (1.-3. Generation)
301/401, 302/402 und 403
(Arpège-Fahrwerke)



TU Dresden WS 2020/21

Beispiel:

AEG/MAN GTx N/M/S



Fahrzeuge des SPNV - Bremsen

Beispiel:

Ansaldo Breda Sirio



Folie 43

Bremse: Einbaumöglichkeiten Lauffahrwerke

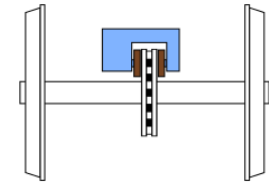
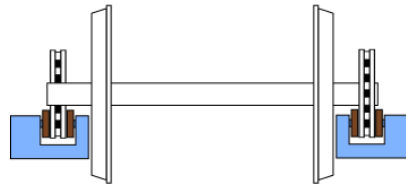
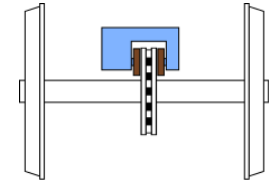
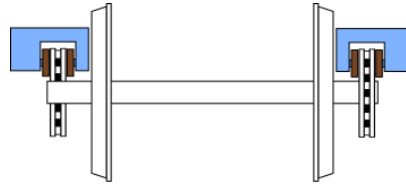

Beispiel:
Bombardier Flexity Classic

Beispiele:
Alstom Citadis X05
(Ixège-Lauffahrwerke)

Beispiel:
Bombardier Flexity Swift

Pesa Twist



Bremsanordnungen (ein Blick in die Werkstatt)

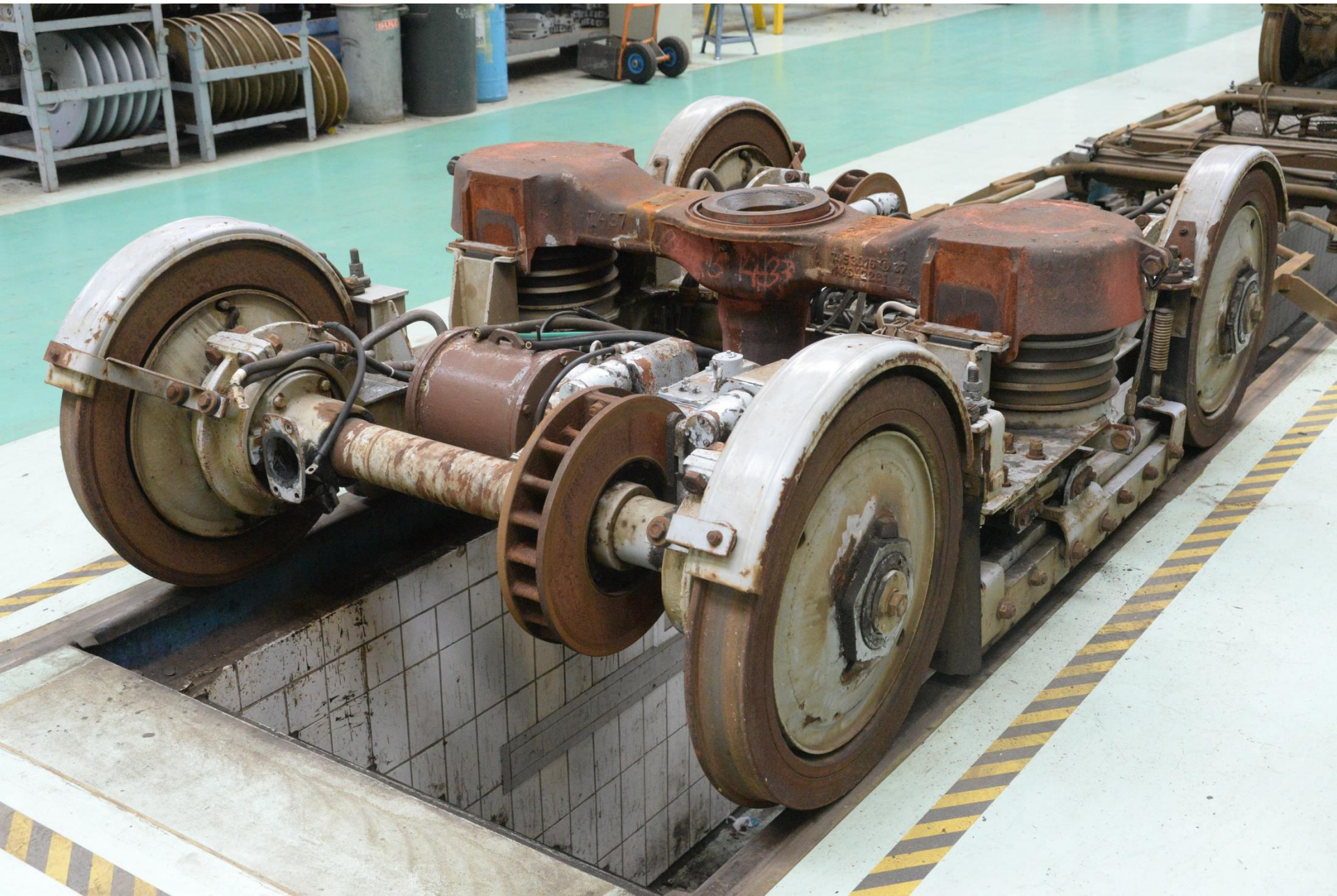

Bremsanordnungen (ein Blick in die Werkstatt)

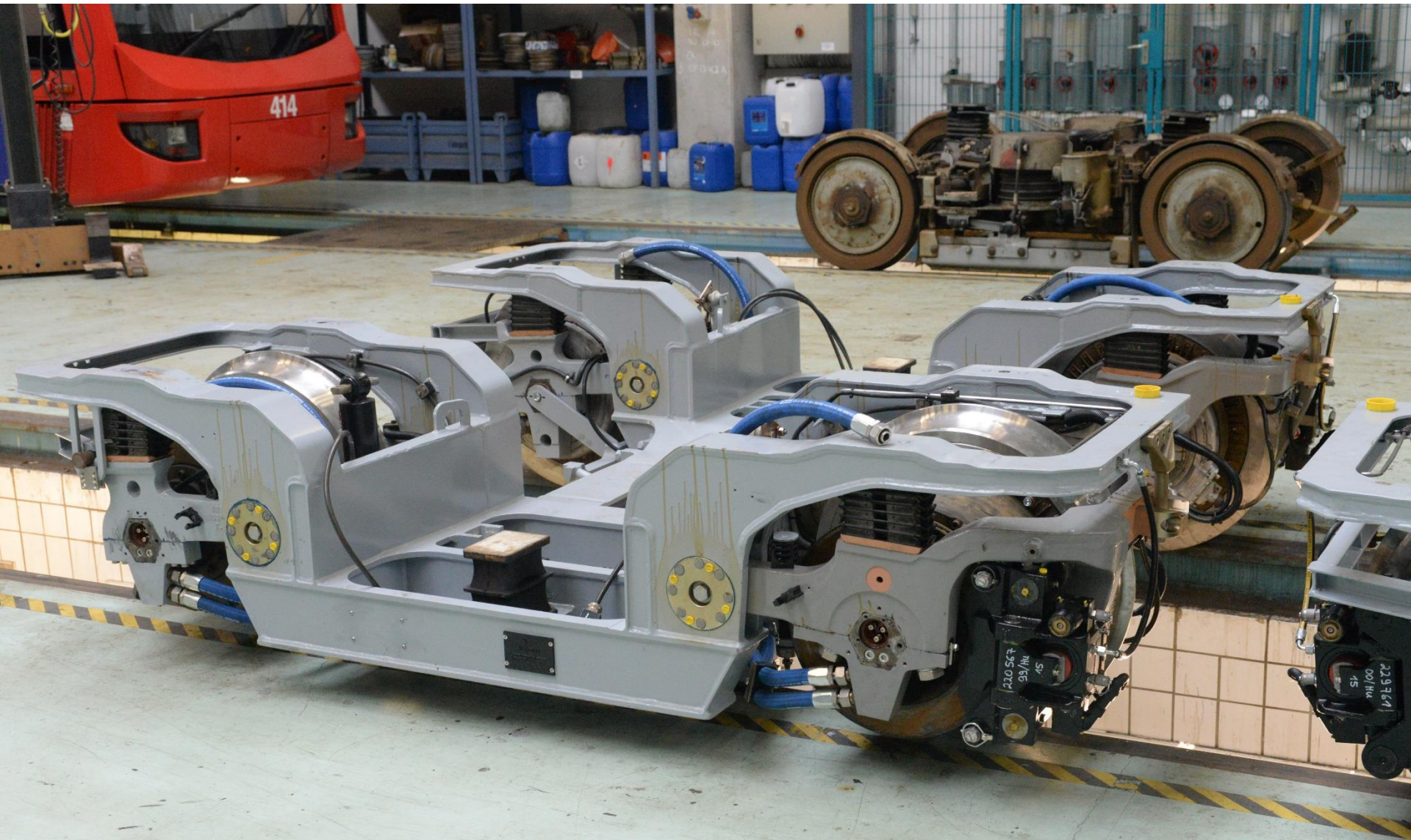

Bremsanordnungen (ein Blick in die Werkstatt)

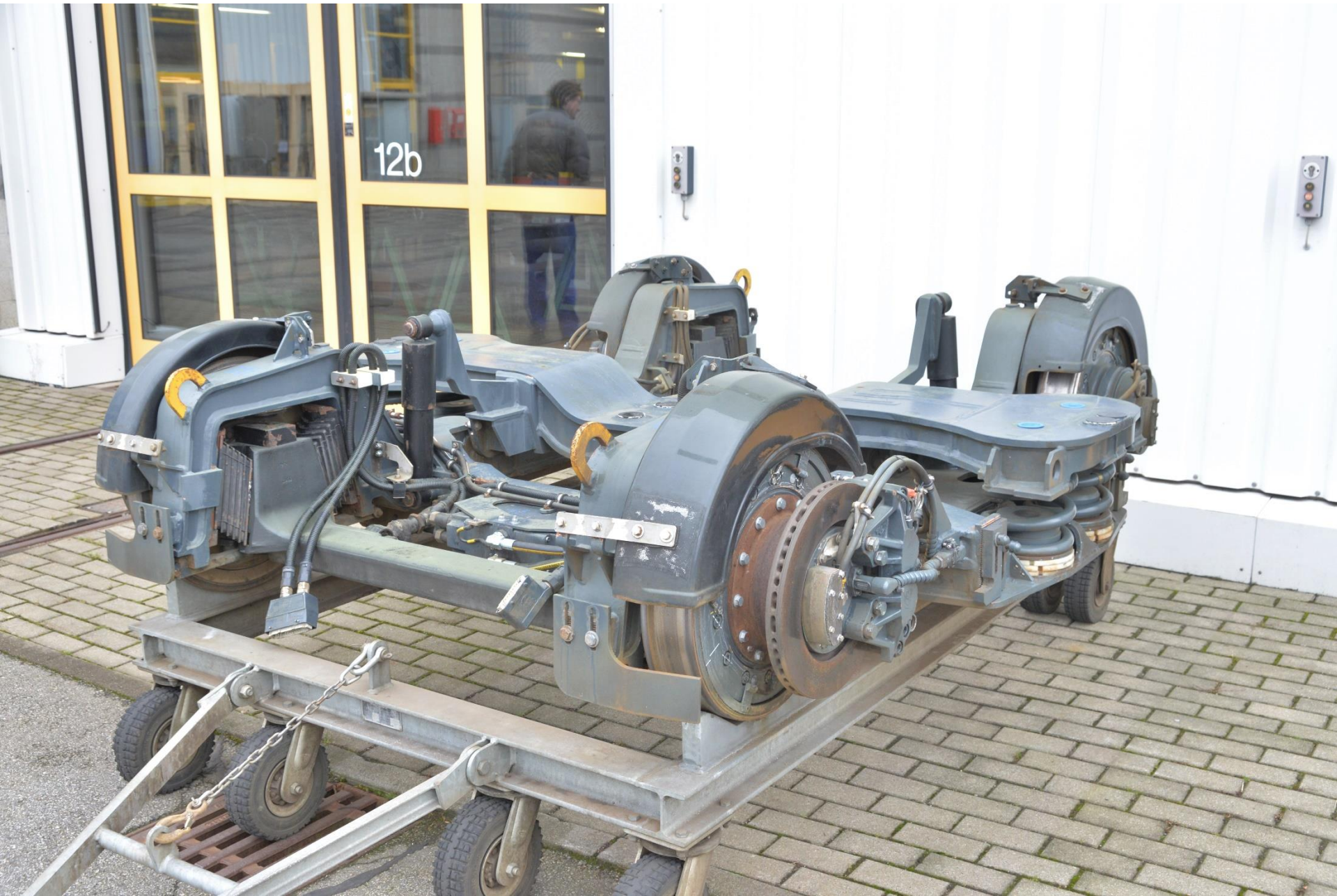

Bremsanordnungen (ein Blick in die Werkstatt)



Bremsanordnungen (ein Blick in die Werkstatt)

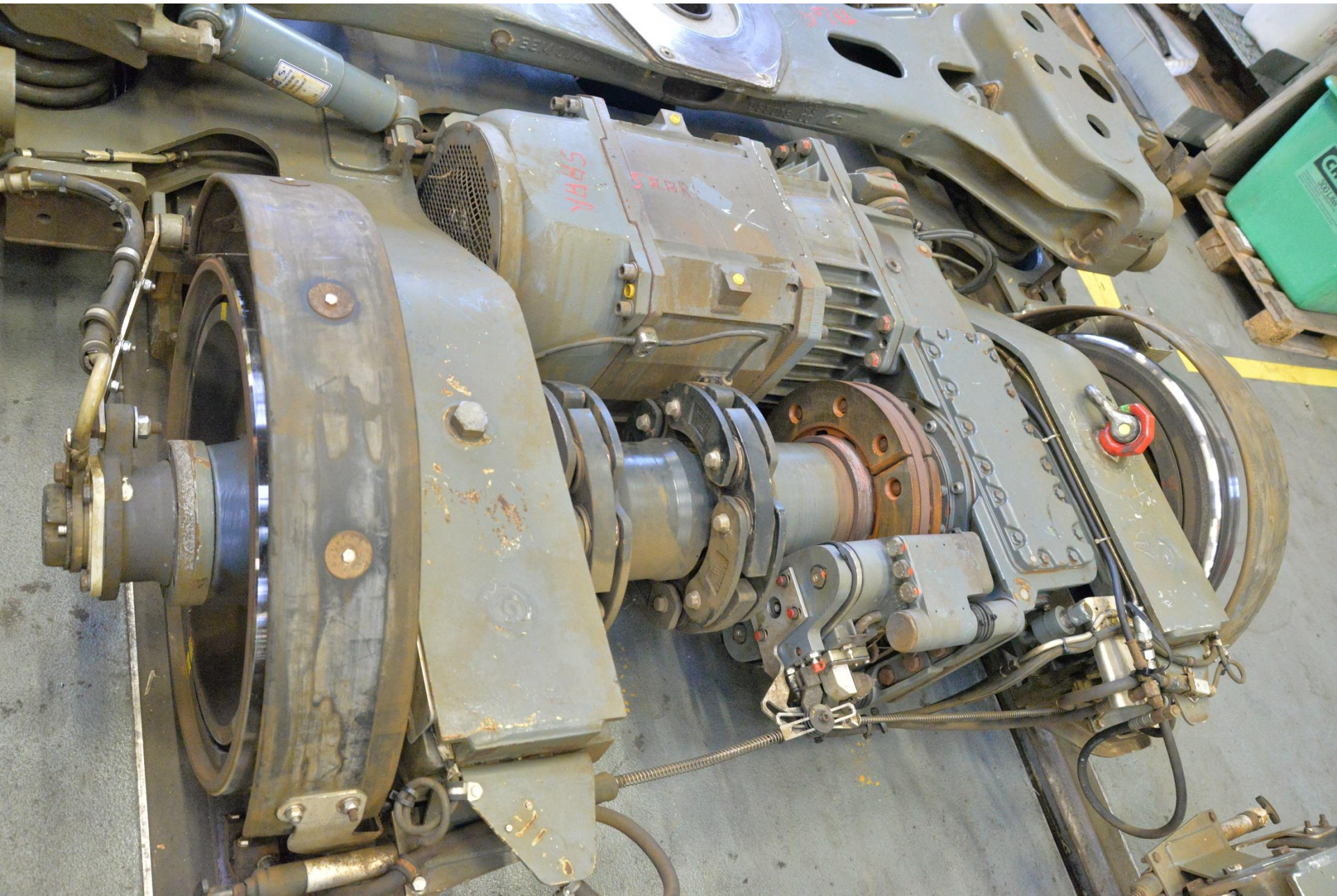

Elektro-Hydraulische Bremsen

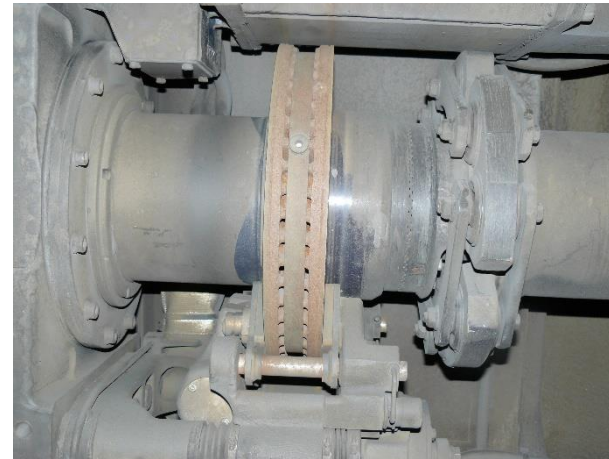
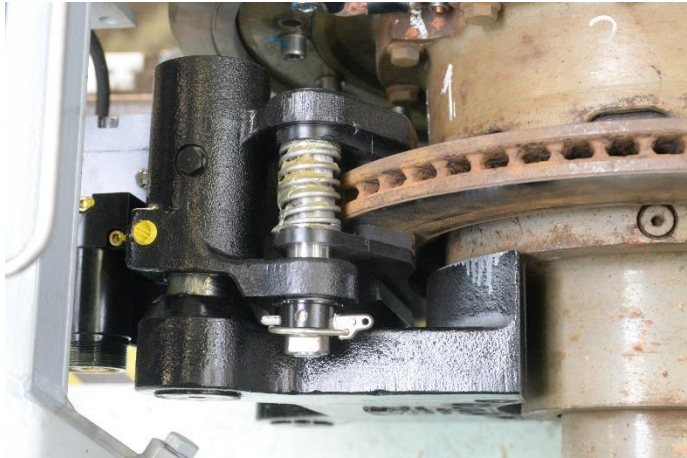

EH-Bremse: prinzipieller Aufbau

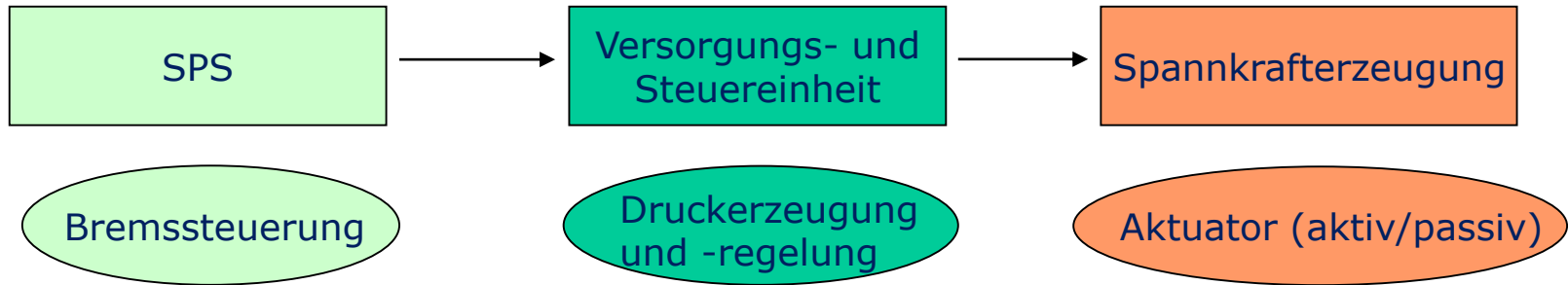

Bremssteuergerät



Hydrogerät
(ggf. mit Hydrospeicher)



Bremskrafterzeuger

Hilfslöse-
einrichtung



Fotos: Hanning & Kahl GmbH & Co KG

Anordnung Hydraulikausrüstung

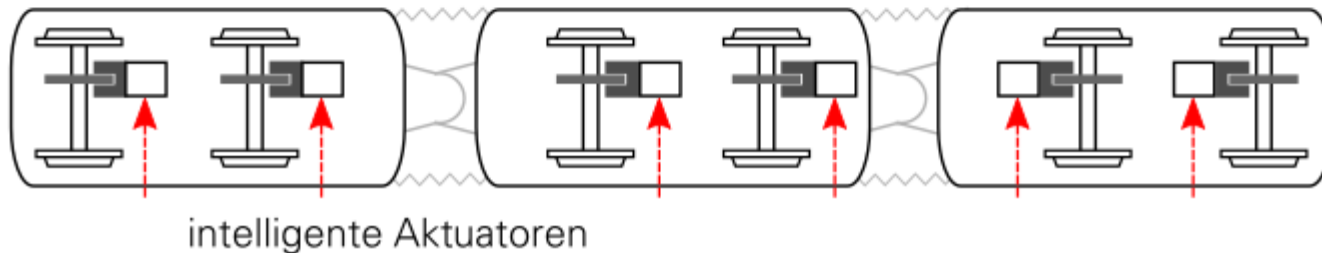
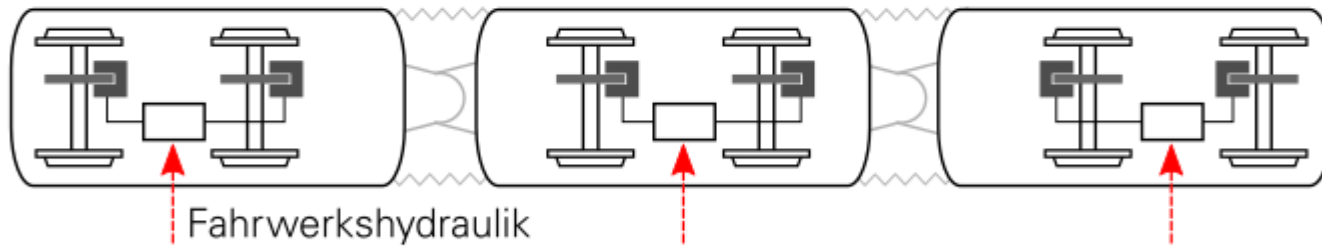
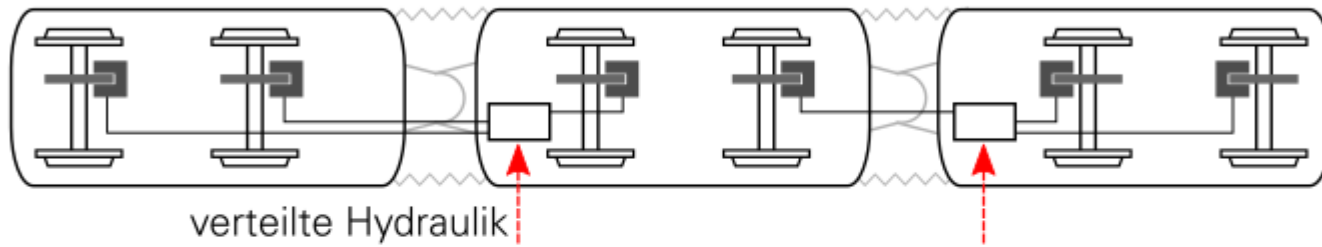
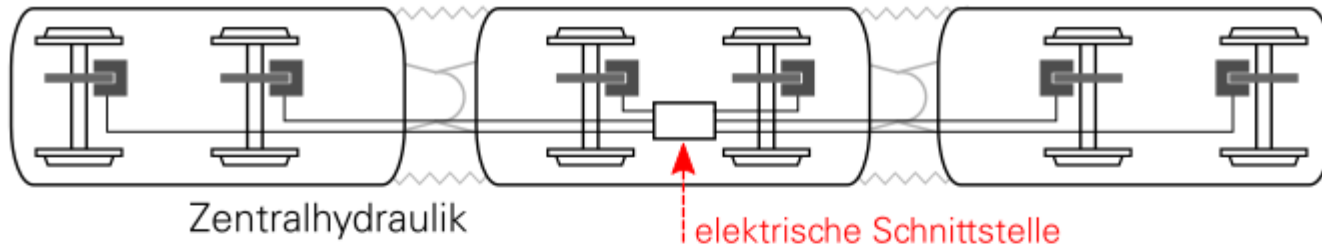

Anordnung Hydraulikausrüstung

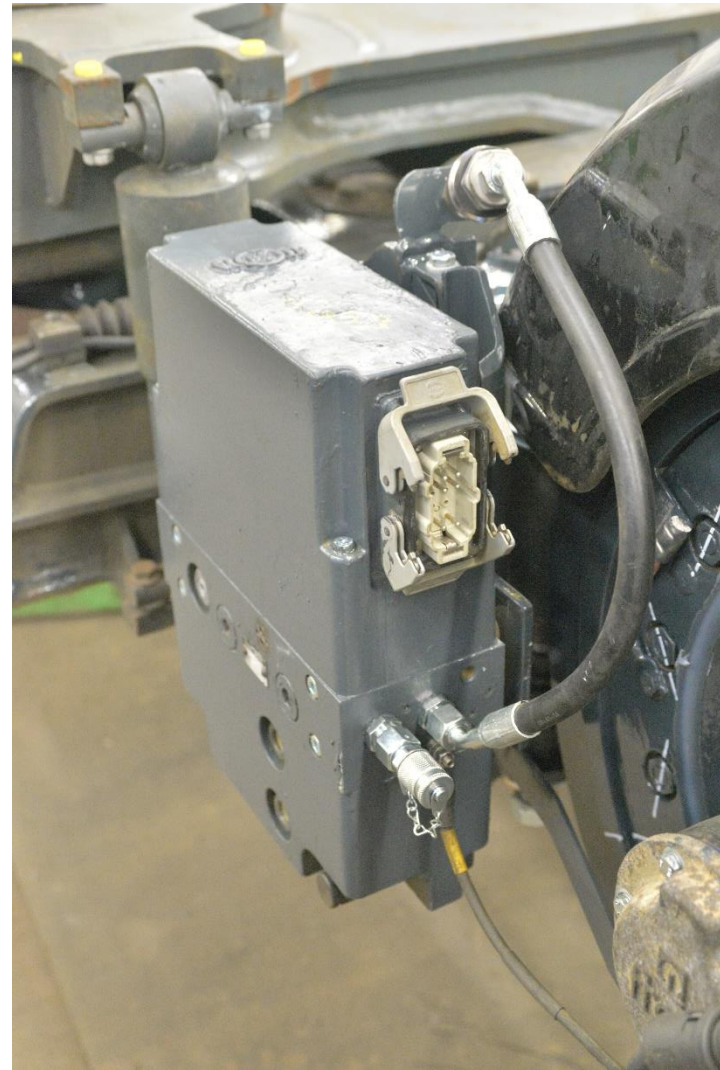
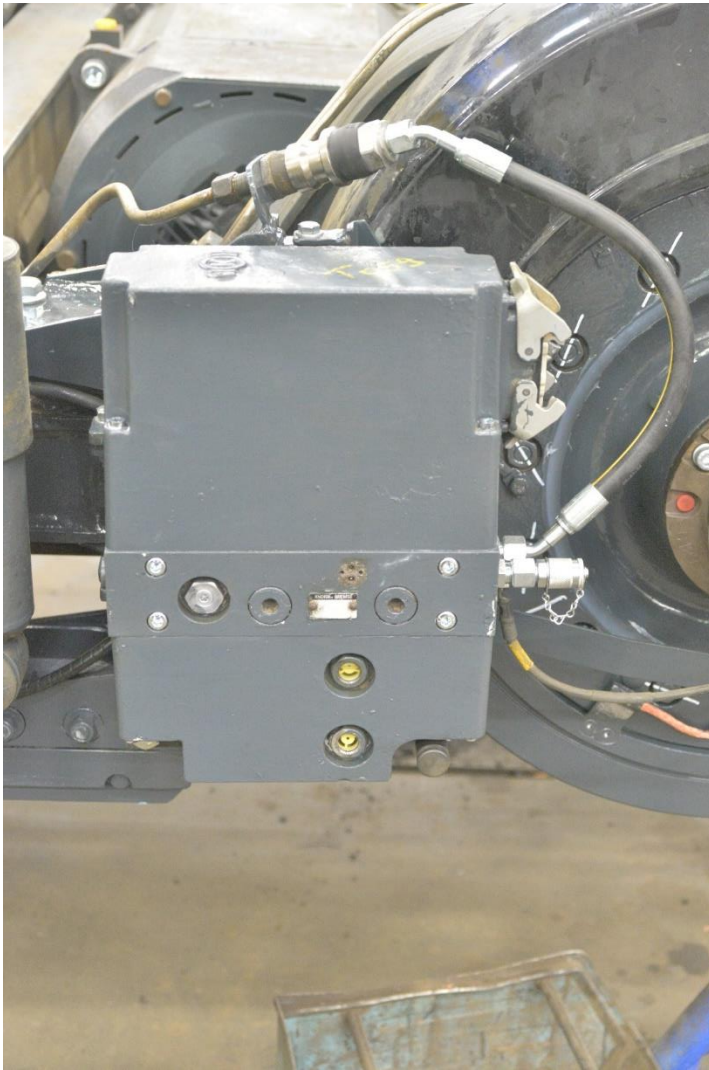

Anordnung Hydraulikausrüstung

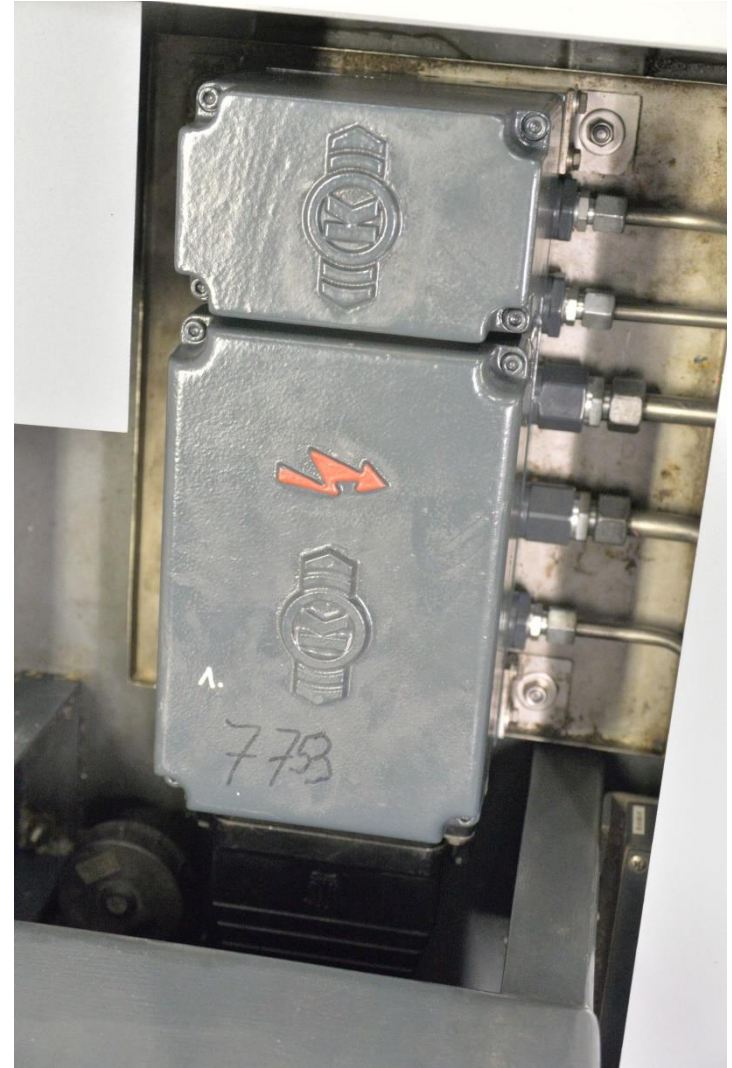

Anordnung Hydraulikausrüstung



EH-Bremse: Aktuator

Bremssattel HH1
P40 im NGT 8 DD

Schwimmsattel

Entlüfter

Bremsbeläge

Kraftpatrone

Haltebolzen
für
Bremsbeläge

Angriff zum
mech.
Notlösen

Rückstellsechskant für
Verschleißnachsteller

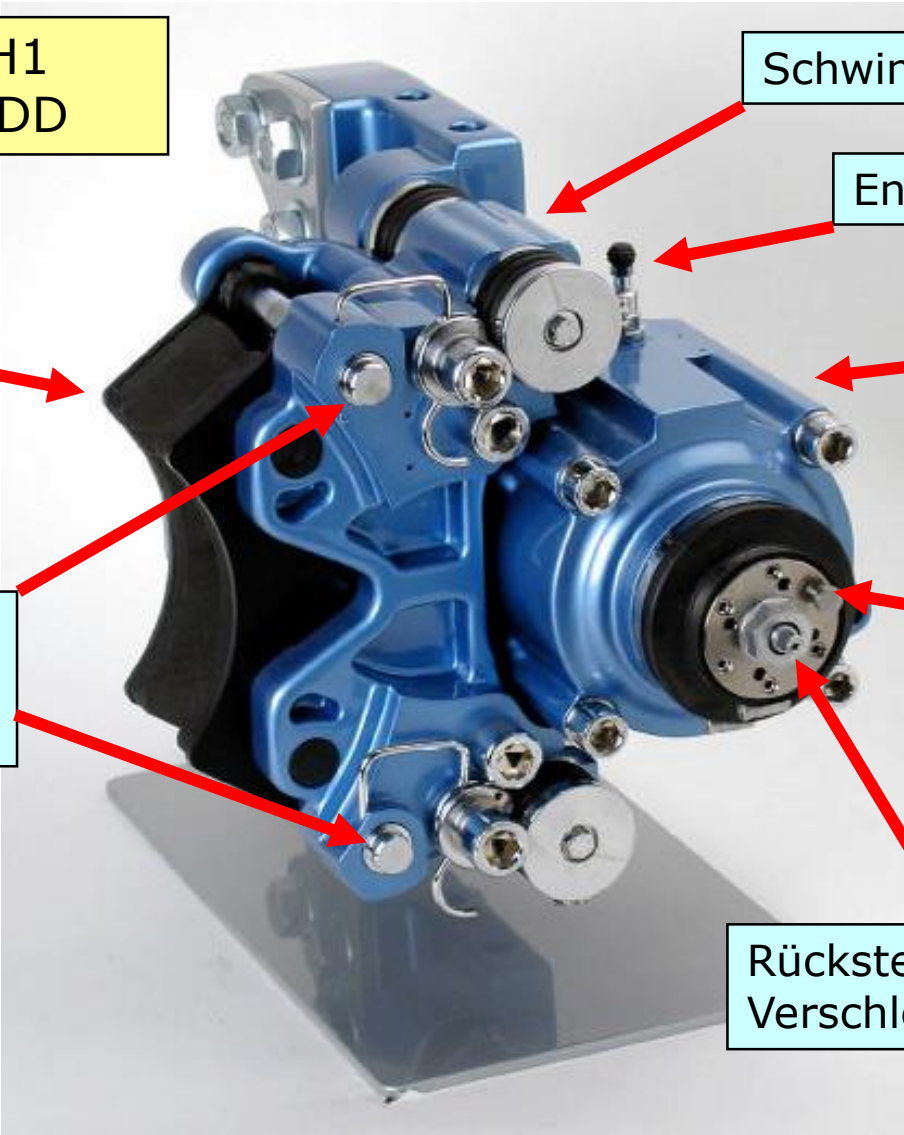

Quelle: R. Frank, DVB AG

EH-Bremse: Aktuatoren (Praxisbeispiele)

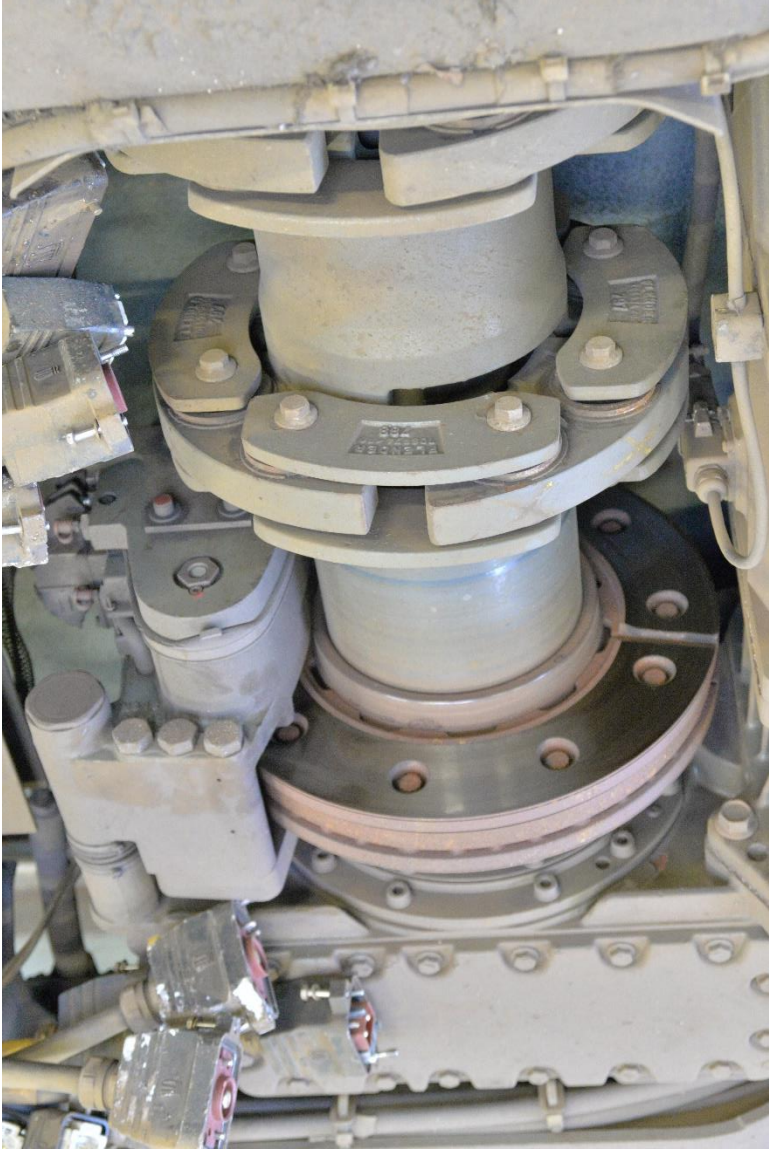

EH-Bremse: Aktuator (Praxisbeispiele)

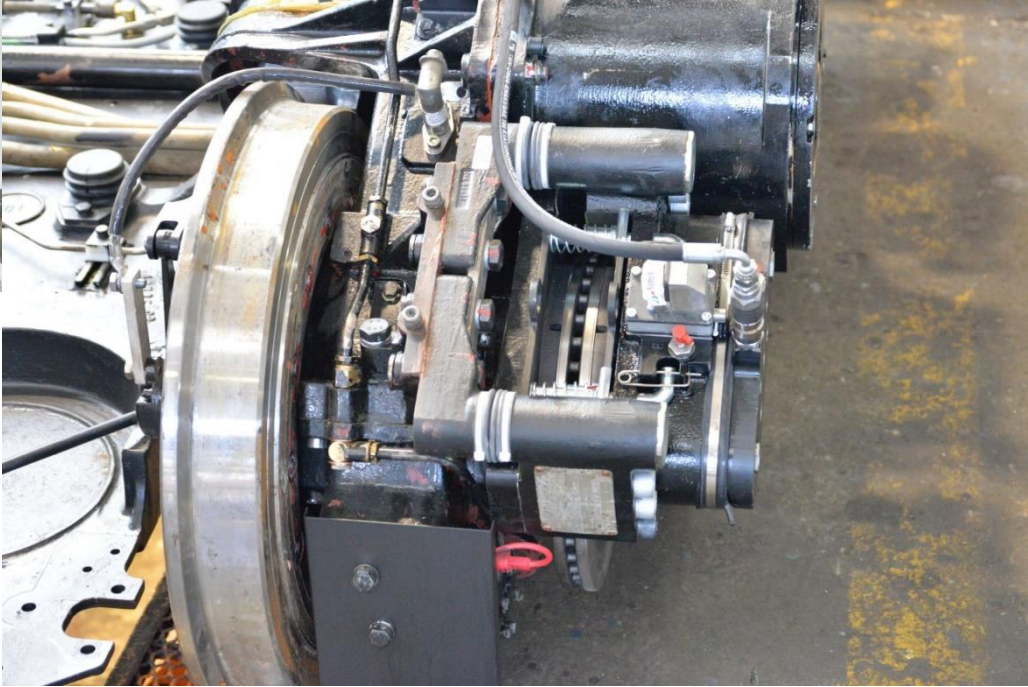

Arten hydraulischer Aktuatoren

Aktiv-Bremse

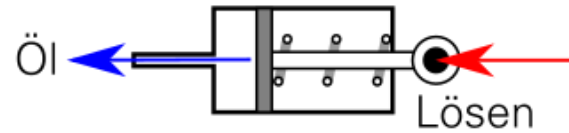
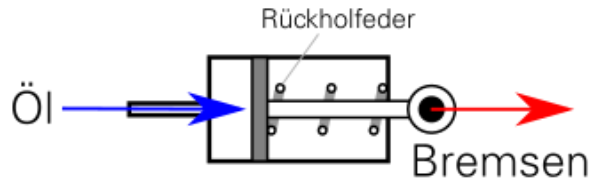

Passiv-Bremse (drückend)

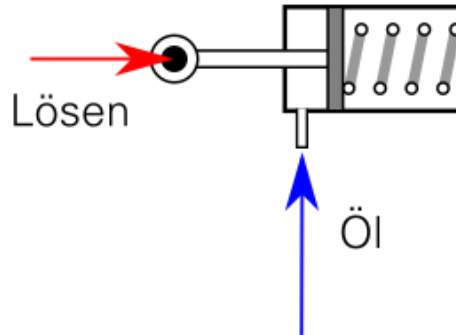
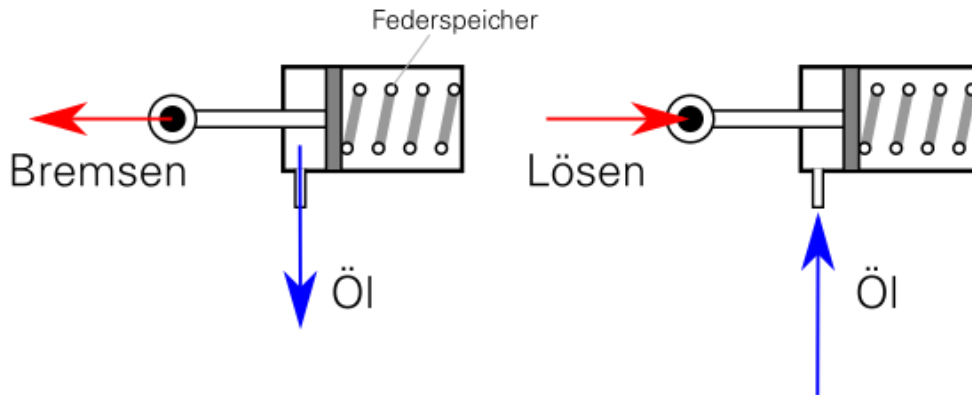

Passiv-Bremse (ziehend)

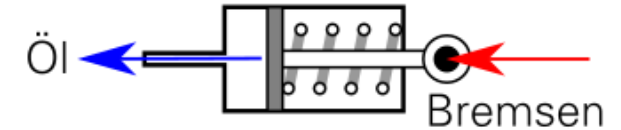
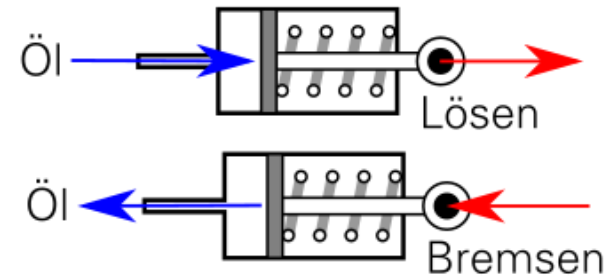

Hydraulische Aktuatoren

typische Spannkräfte

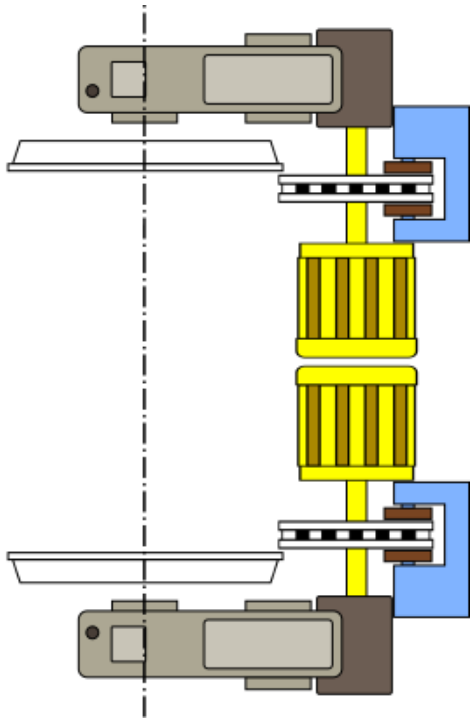

4-10 kN

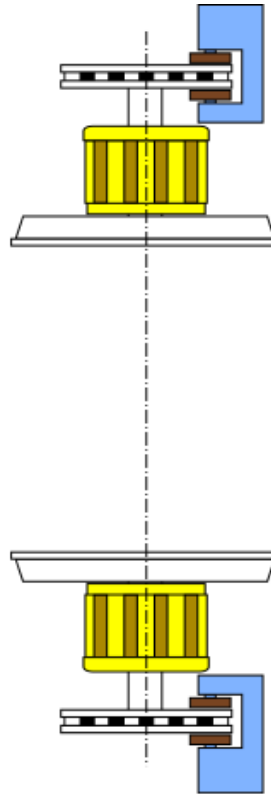

15-20 kN

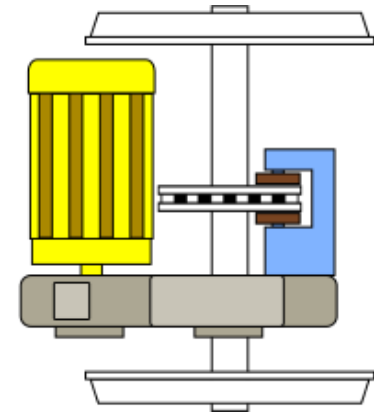

30-40 kN

EH-Bremse: Anordnung Bremskrafterzeuger I

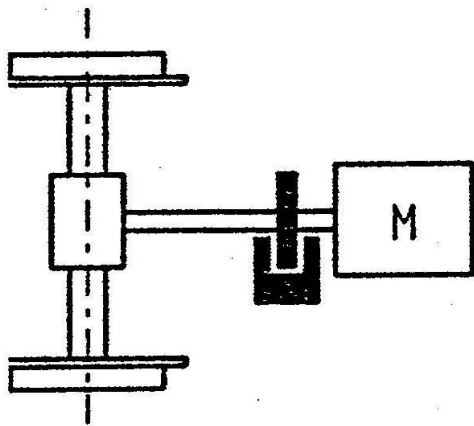

Motorwellenbremse

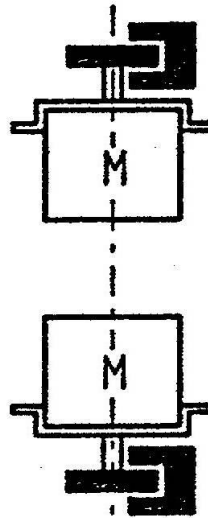

Radbremse

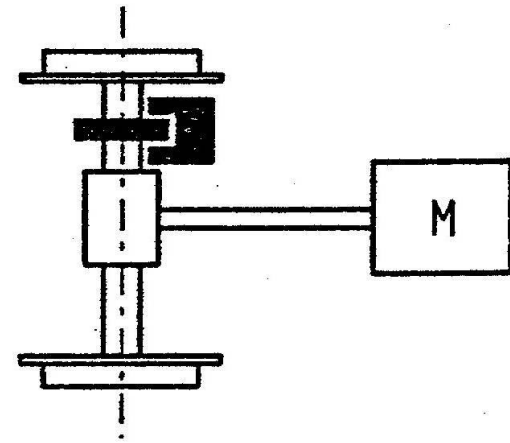

Radsatzwellenbremse

nach Kipp in: ZEV + DET Glas. Ann. 11/12 1995

EH – Bremse: Anordnung Bremskrafterzeuger II

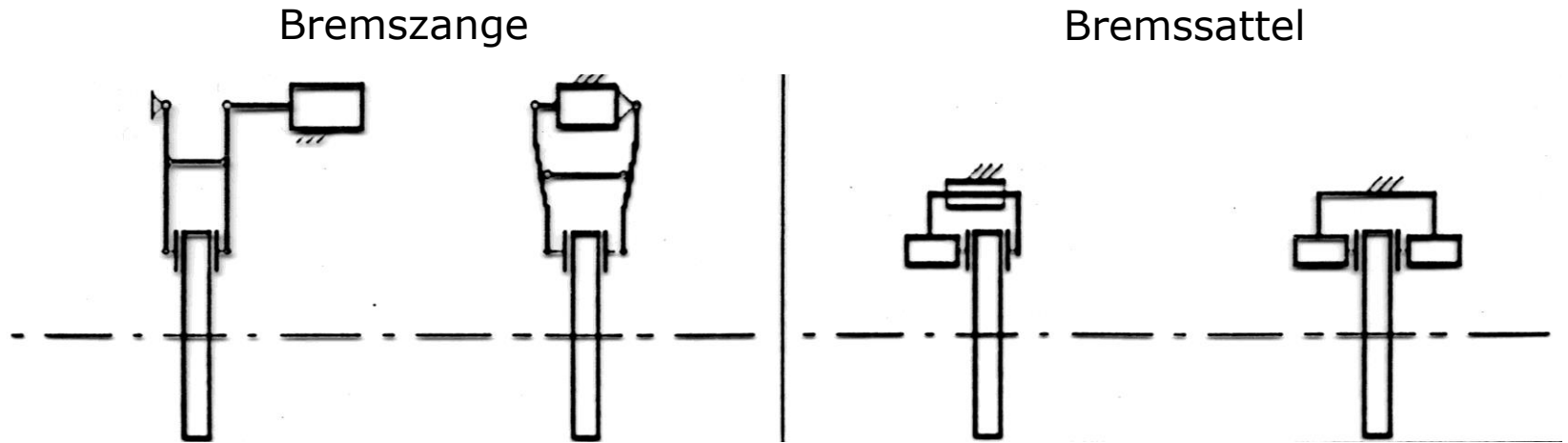

Anordnung des Bremskrafterzeugers:

seitlich /
außen liegend

zwischen den
Zangen /
innen liegend

einseitig

Sattel schwimmend gelagert
(Schwimmsattel)
mit 1 oder 2 Kraftpatronen
auf *einer* Seite

zweiseitig

Sattel fest gelagert
(Festsattel)

Hydrogerät zweistufig – Lösestellung

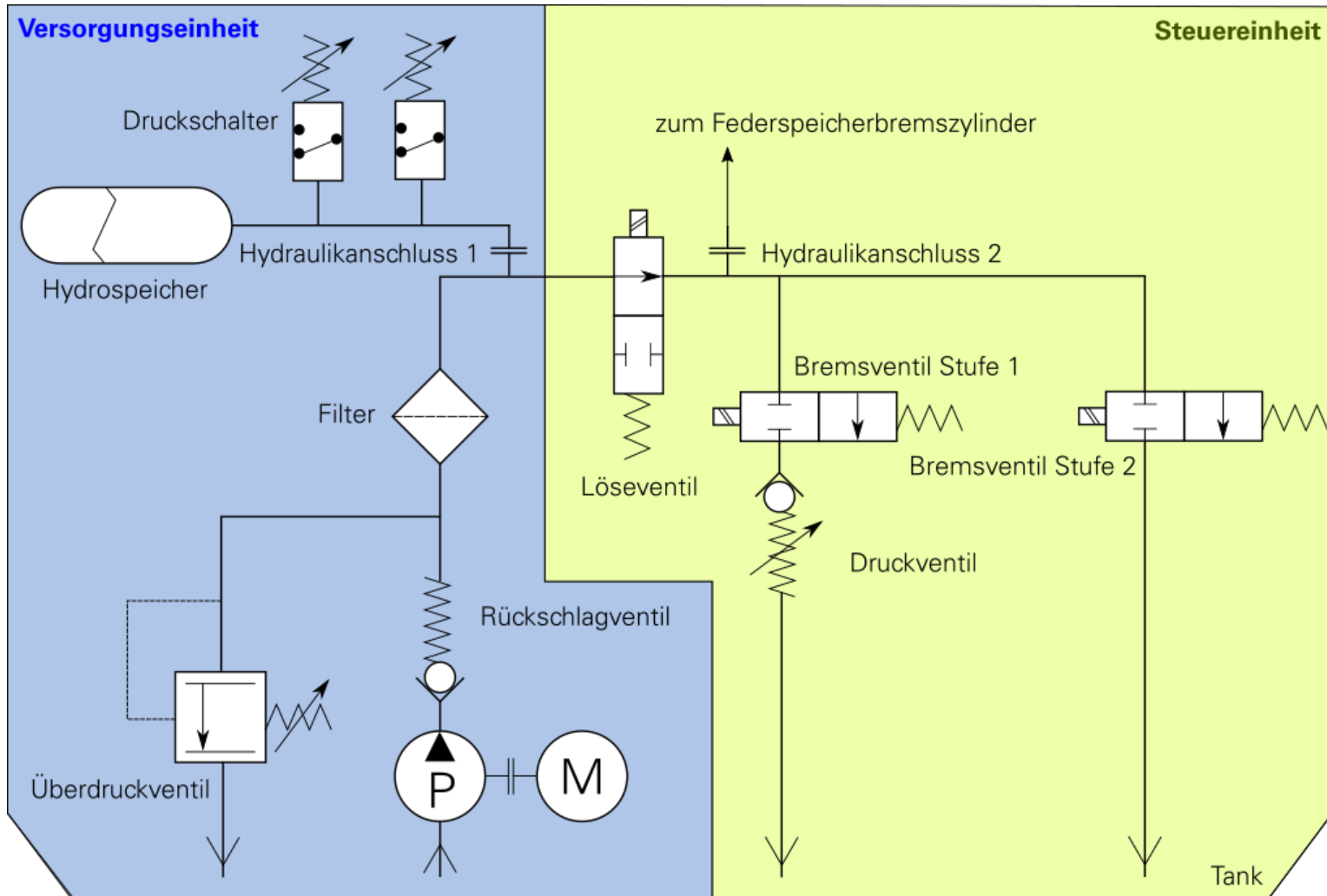

Hydrogerät (Werkstatt, I)



Hydrogerät (Werkstatt, II)

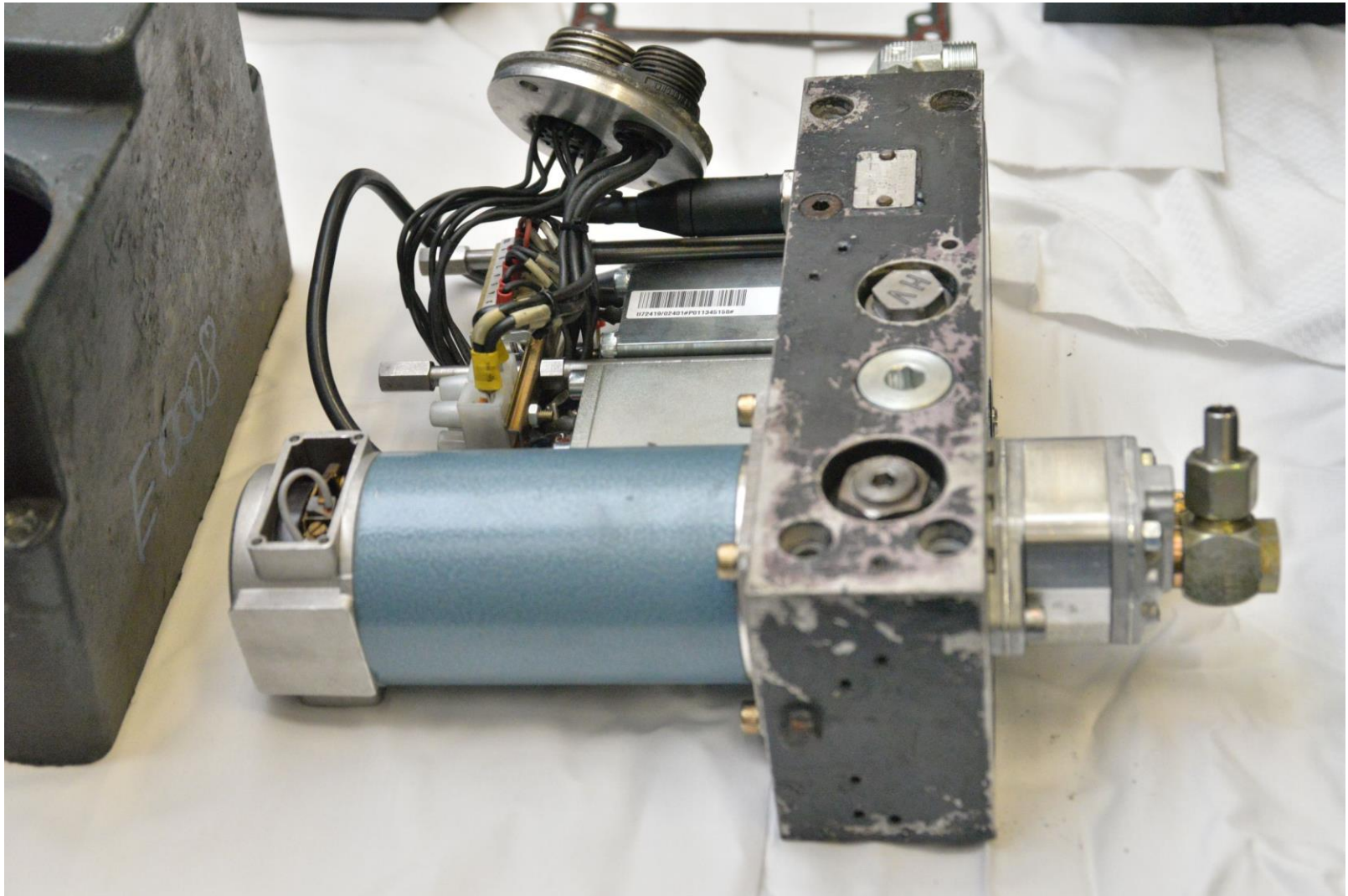

Hydrogerät (Werkstatt, III)

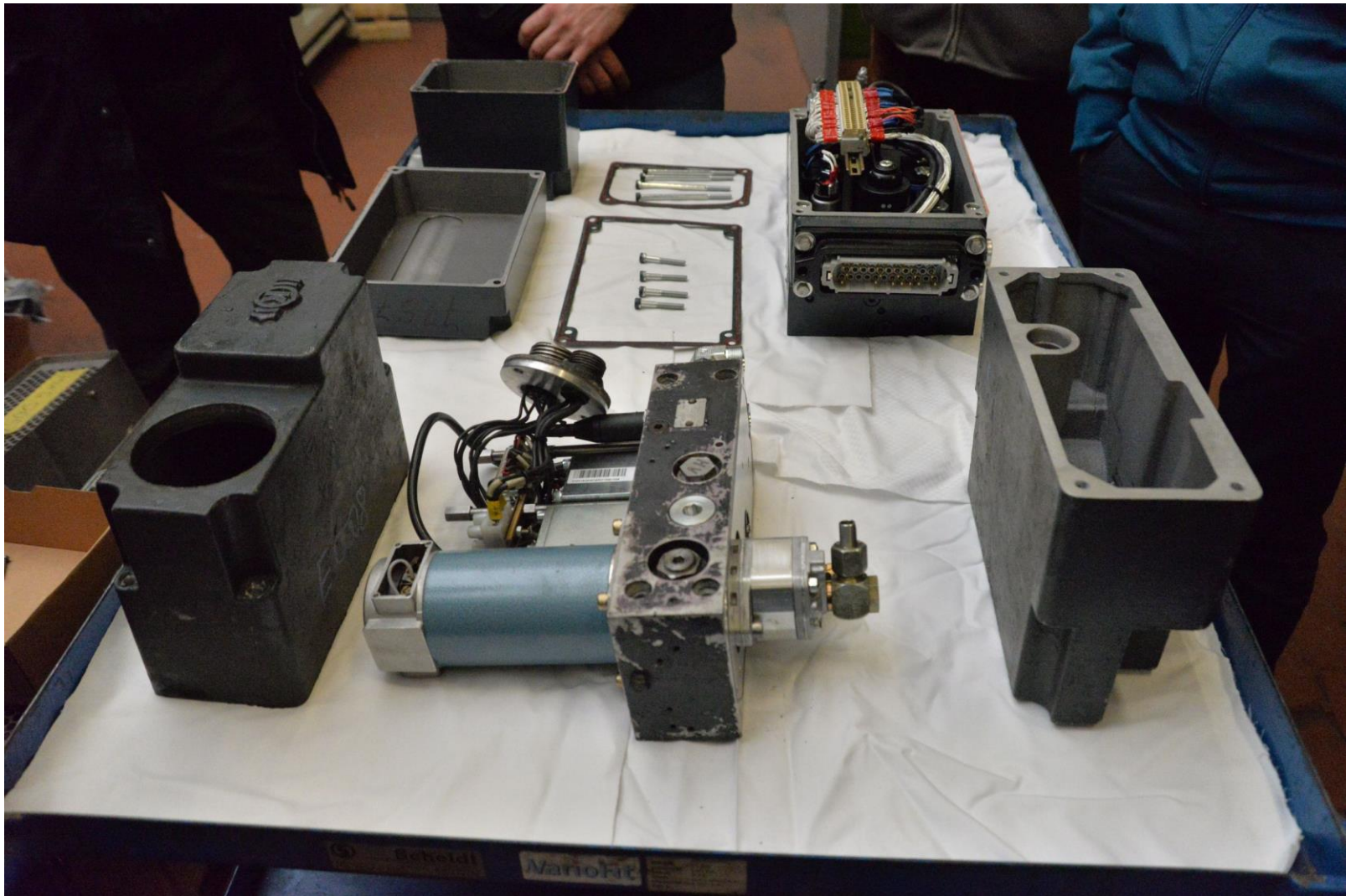

Hydrogerät (Werkstatt, IV)

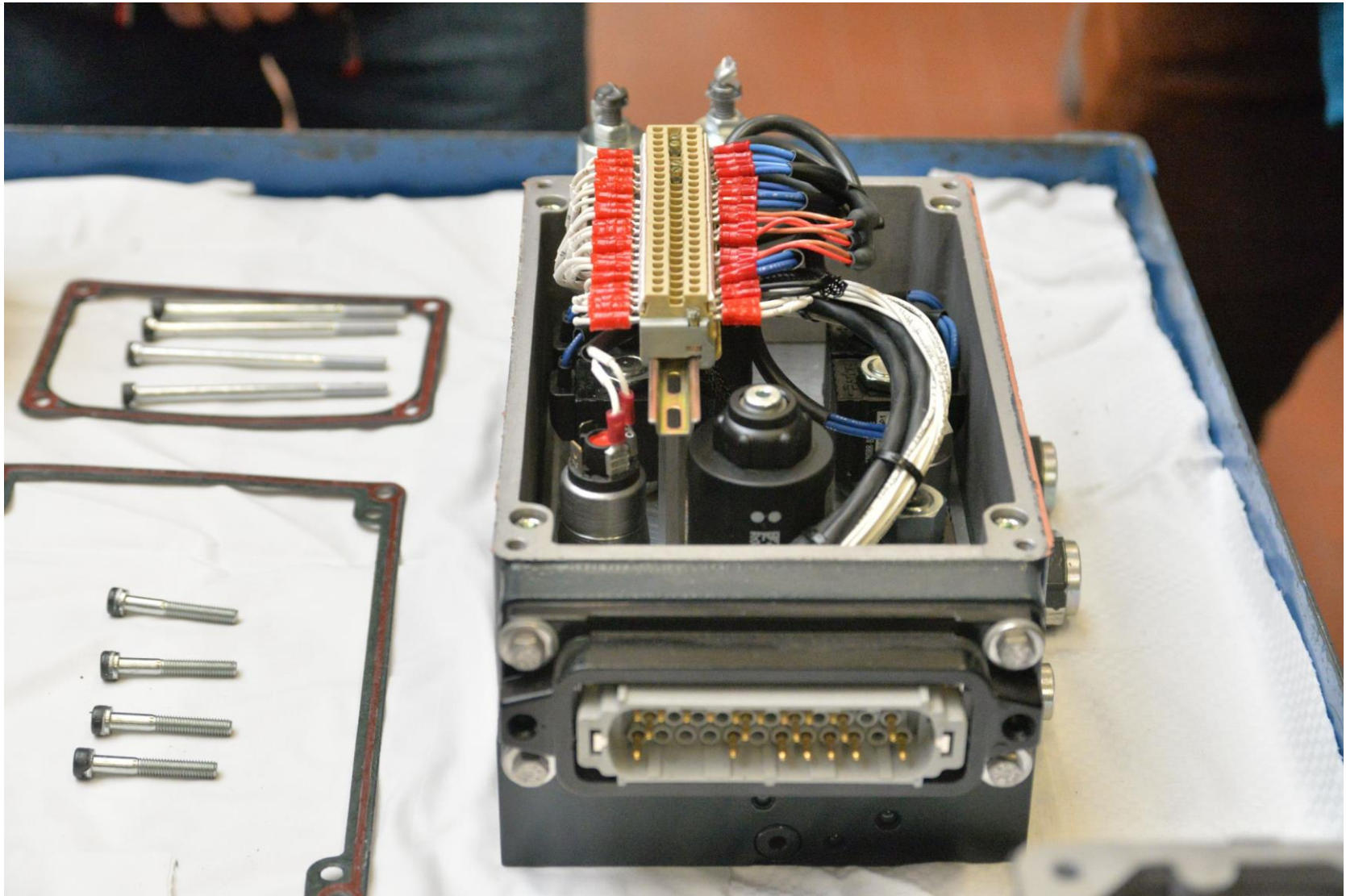

Hydrogerät zweistufig – Lösestellung

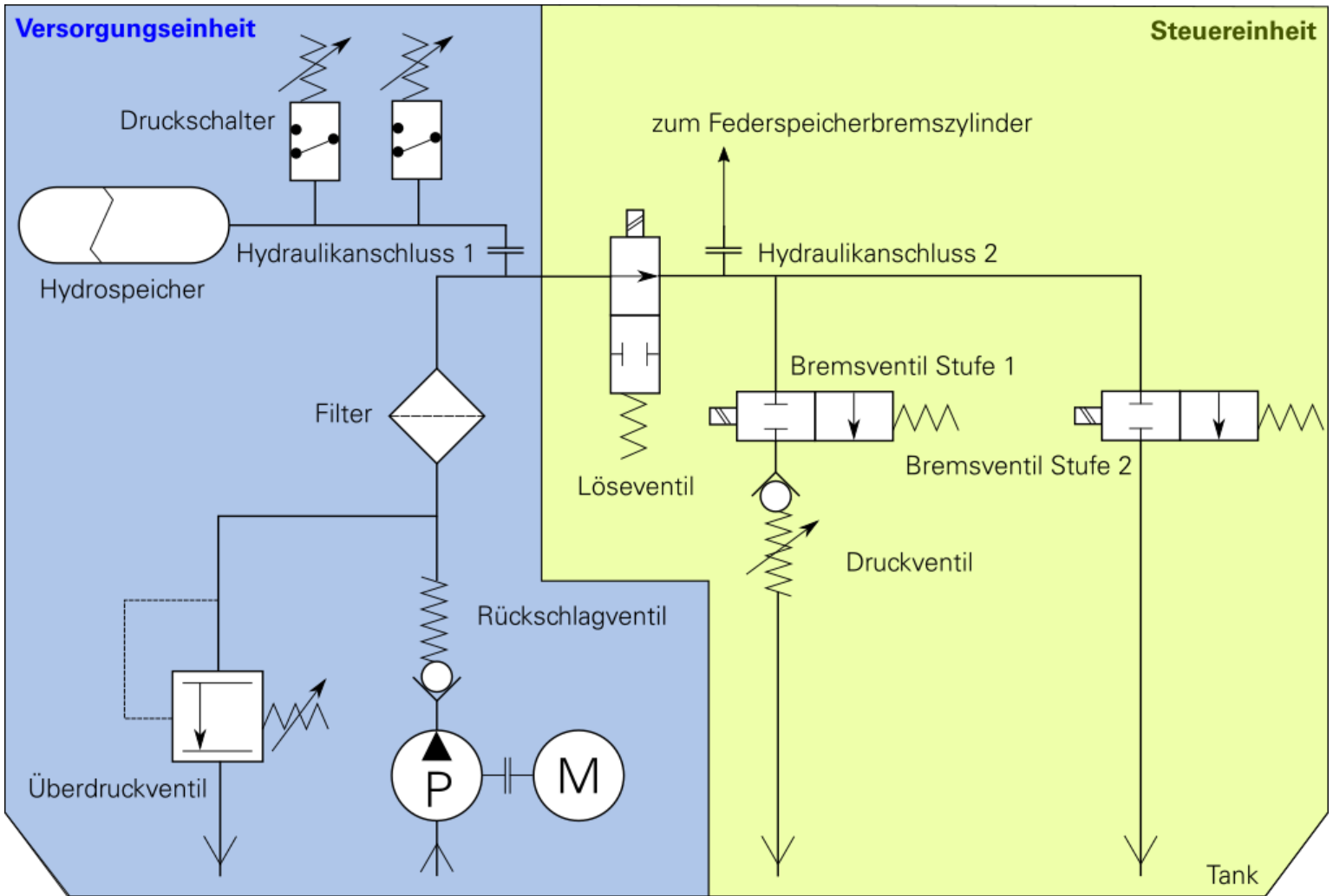

Hydrogerät zweistufig – Bremsstufe 1

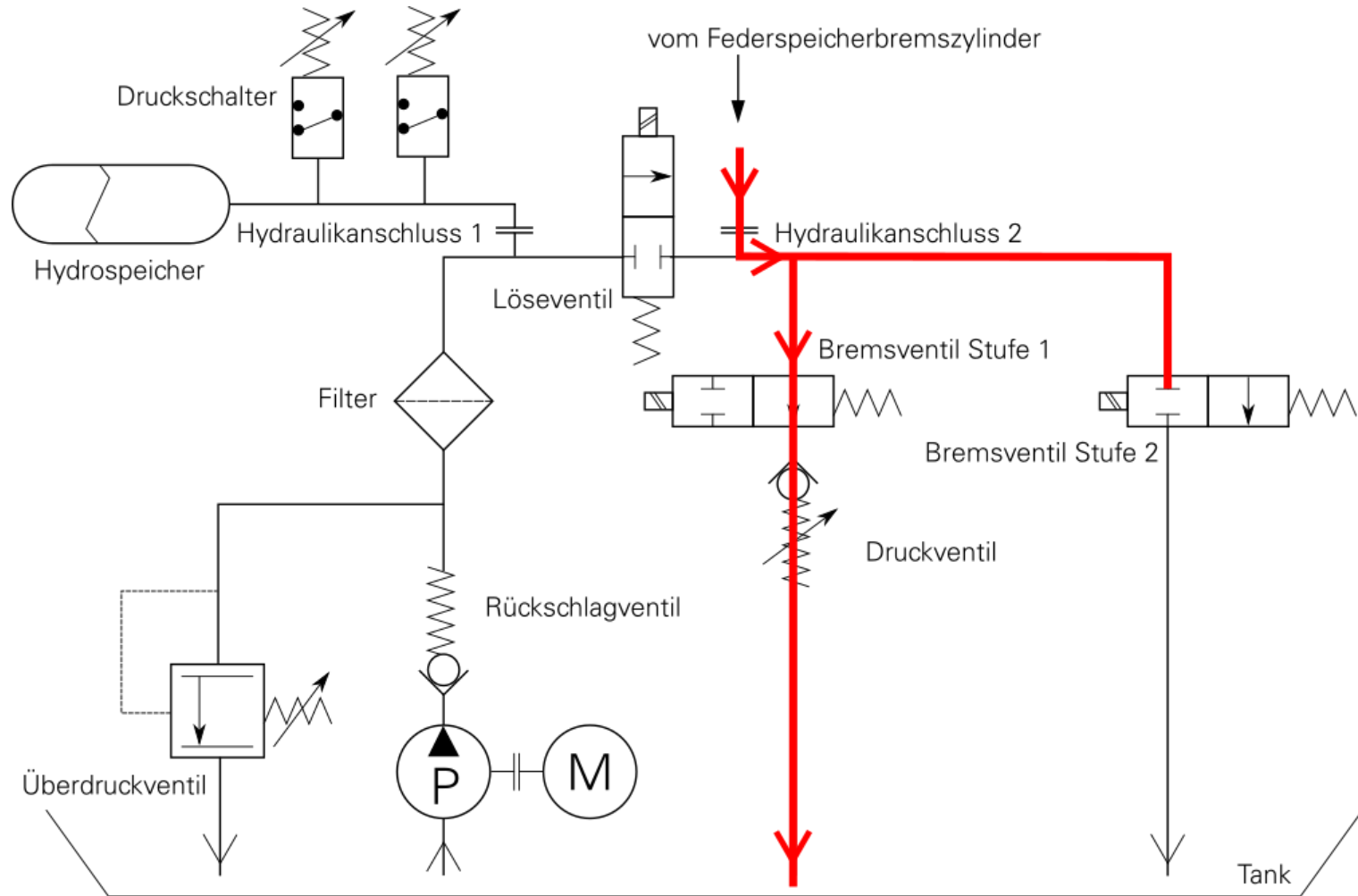

Hydrogerät zweistufig – Bremsstufe 2

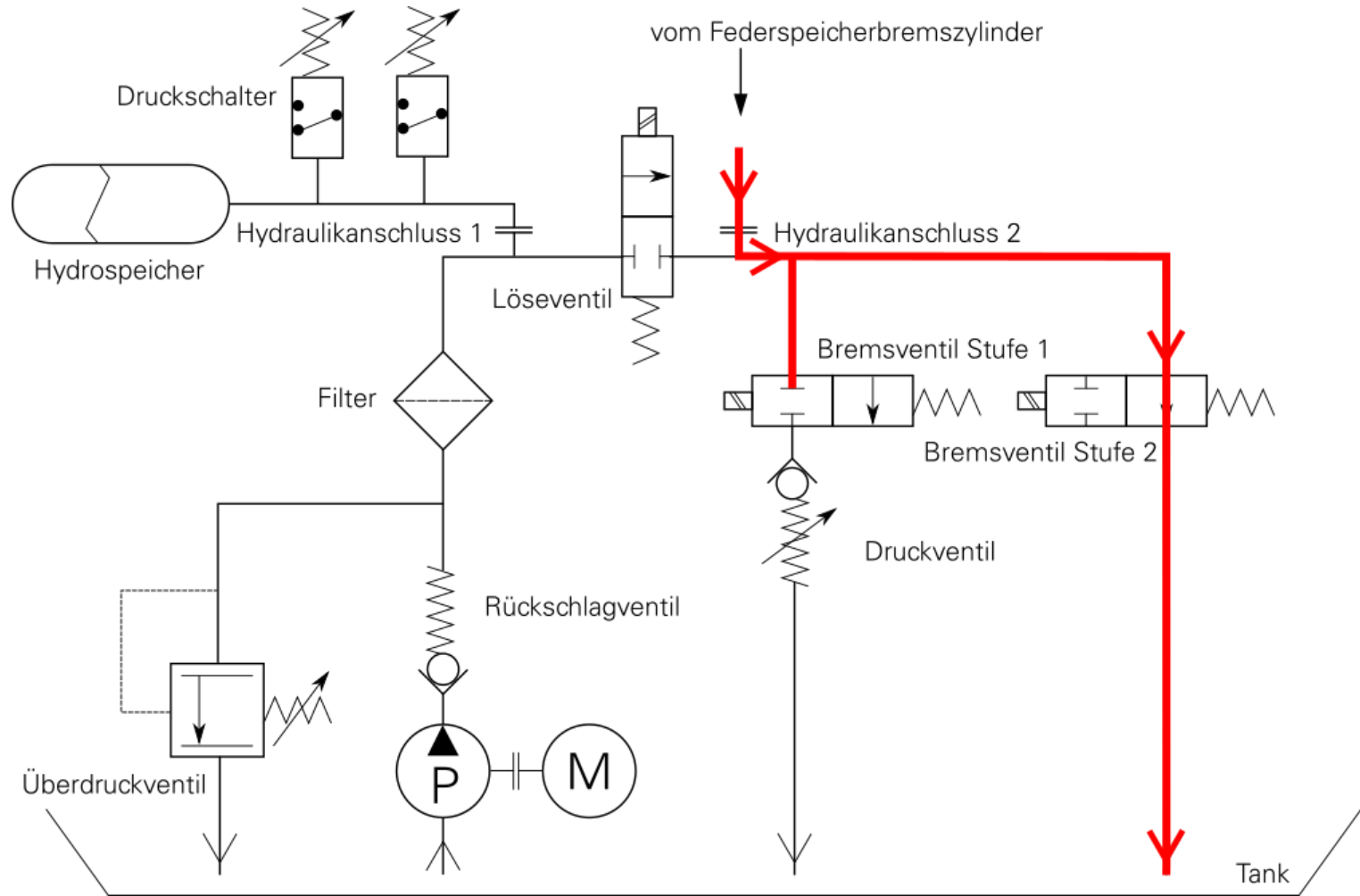

Hydrogerät stufenlos (Passivbremse)

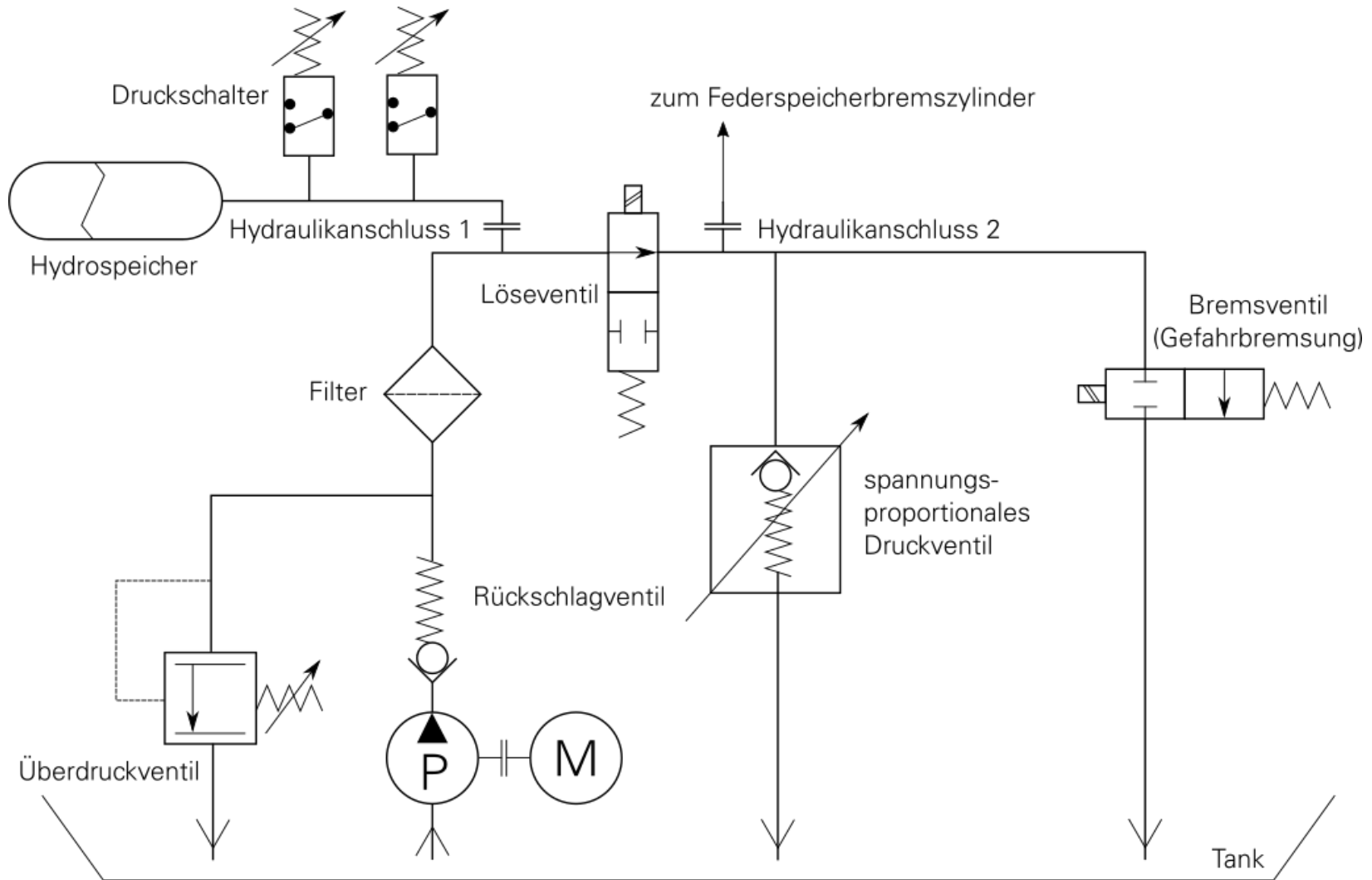

Hydrogerät stufenlos (Aktivbremse)

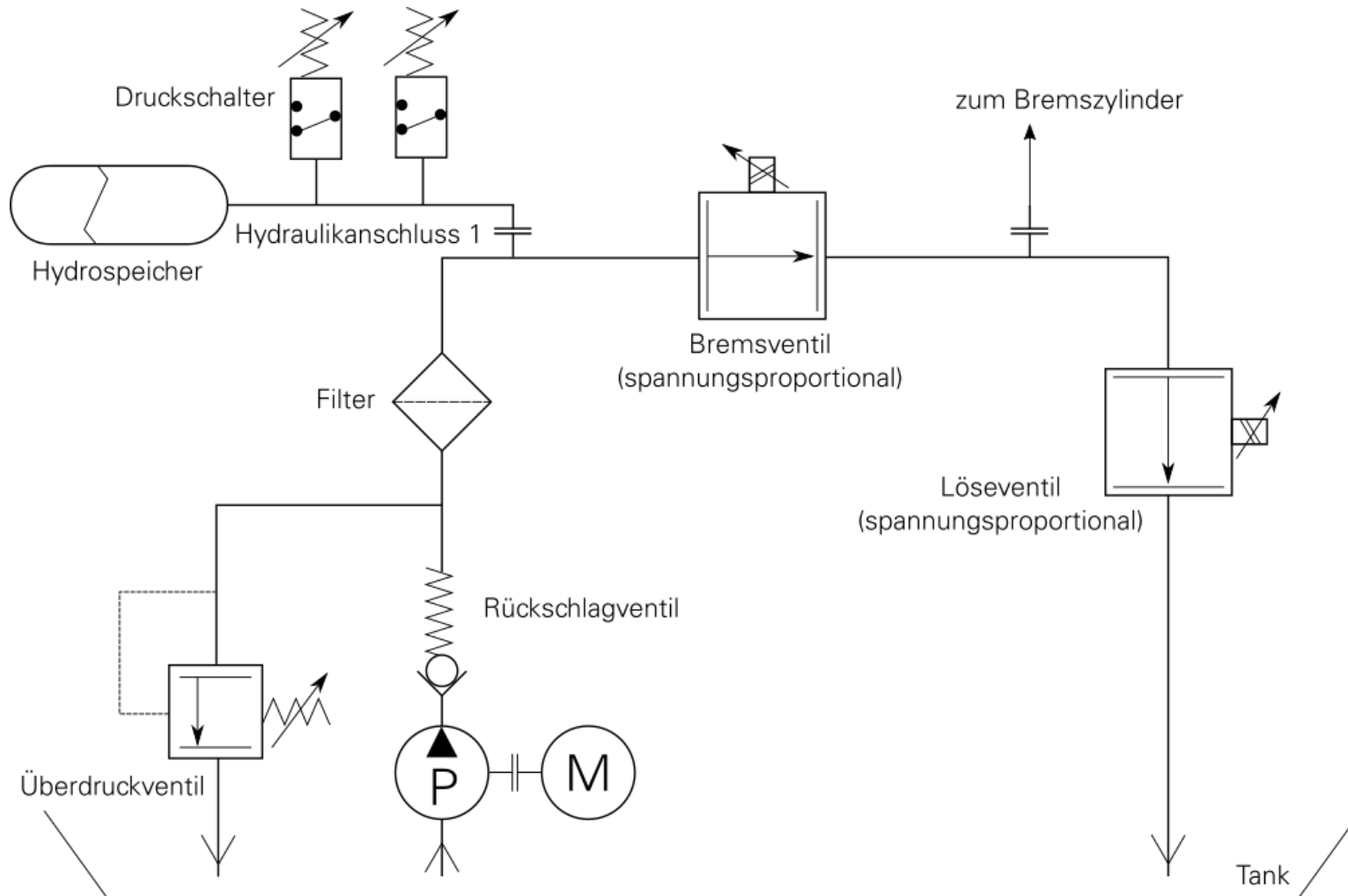

Beispiel EH – Bremse

NGT8D MAGDEBURG

Triebdrehgestelle:

- Federspeicher-Bremssättel
- zweistufige DG-Hydraulik

Laufdrehgestelle:

- LD2 ungebremst
- LD1 vier aktive Schwimmsättel und 2-kanaliges proportionales Hydrogerät
- mit Gleitschutzüberwachung

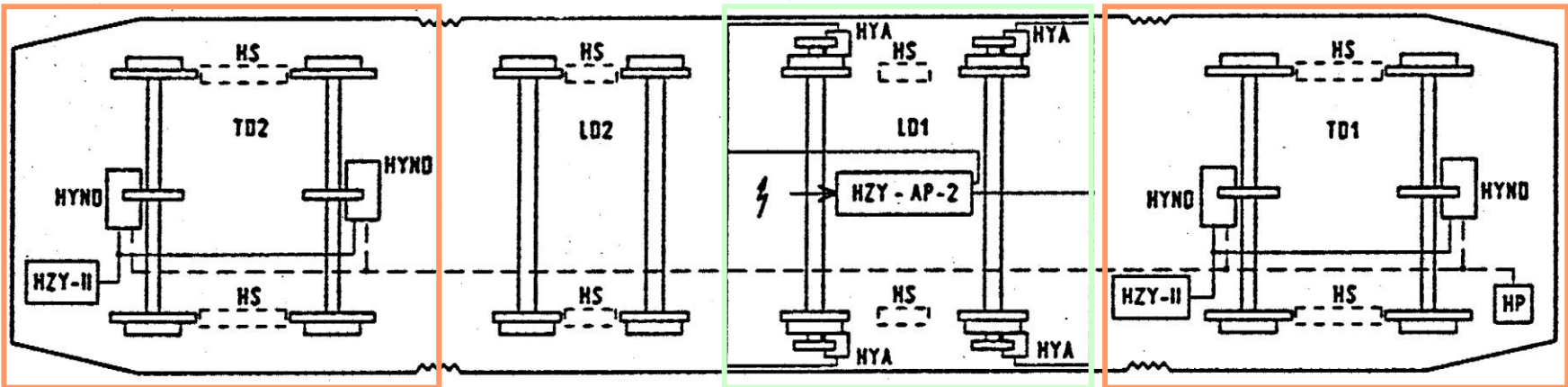

Quelle: Hannig & Kahl

Beispiel EH – Bremse

R3 FRANKFURT

Triebdrehgestelle:

- 2 von 4 Rädern ungebremst
- Brems­sättel und DG übergreifendes 2-kanaliges proportionales Hydrogerät

Laufdrehgestell:

- vier Federspeicherbrems­­sättel
- mit Gleitschutzüberwachung



(c) Bernd Kittendorf, 2006

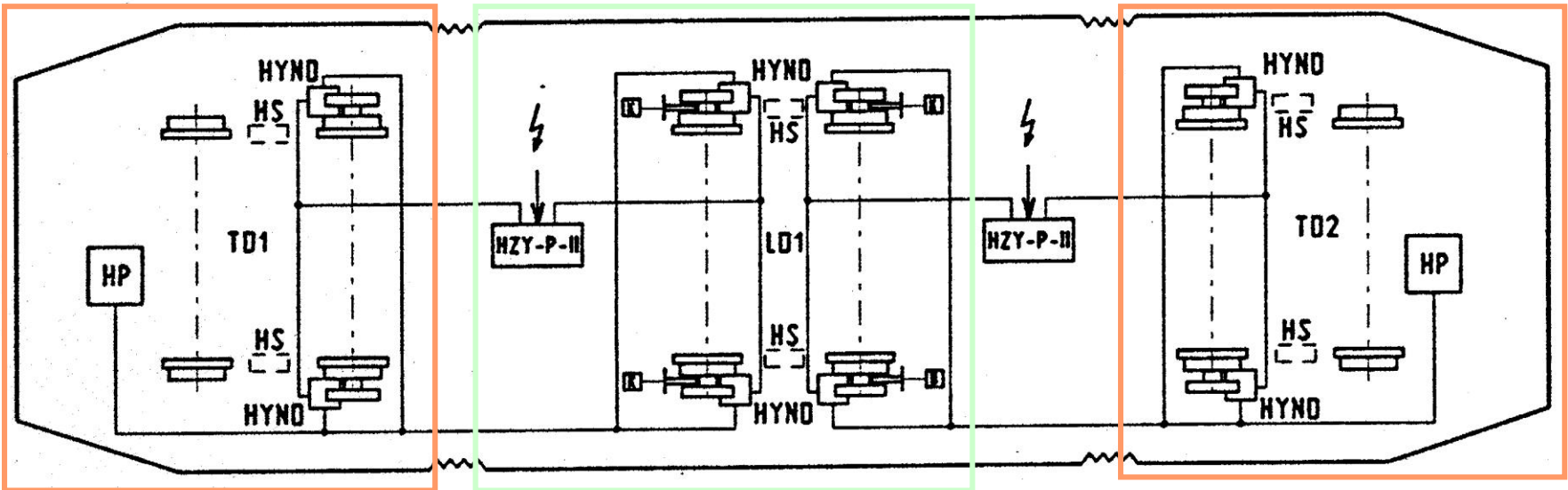

Beispiel EH – Bremse

GT6M-NF ZWICKAU

- 3 identische Triebdrehgestelle
- zweistufige Federspeicherbremsgeräte auf Motorwellen

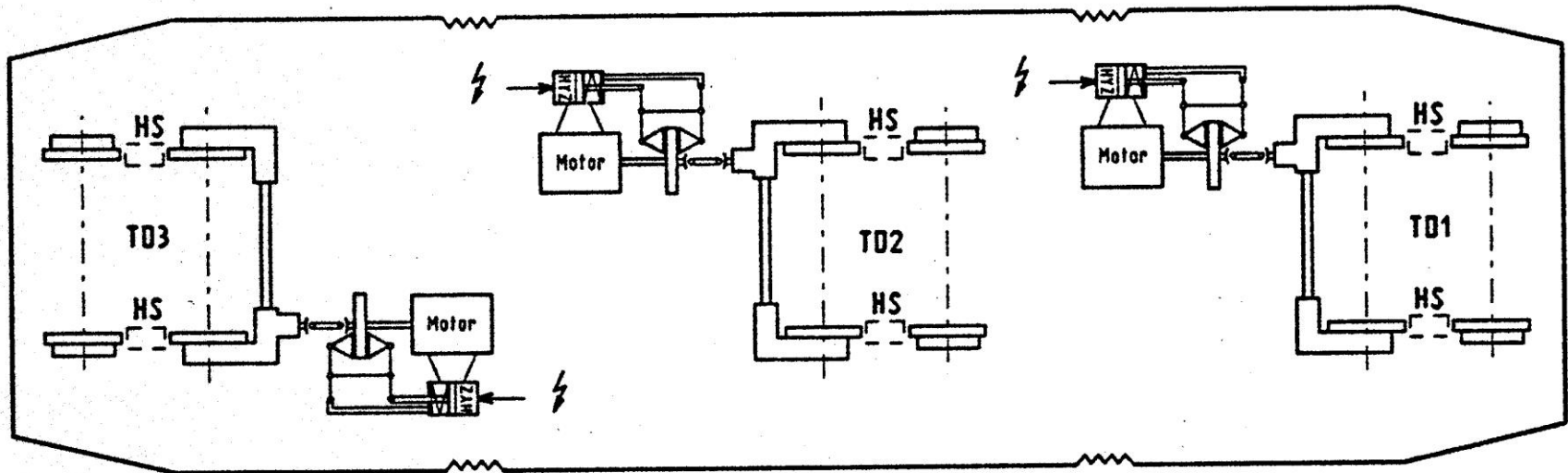

Quelle: Hannig & Kahl

Beispiel EH – Bremse

BOMBARDIER FLEXITY CLASSIC

- 2 Trieb- und zwei Laufdrehgestelle
- Laufdrehgestelle mit aktiven Bremssätteln (stufenlos)
- Triebdrehgestelle mit Federspeicher-Bremssätteln (gestufte Ansteuerung)
- Drehgestellhydraulik

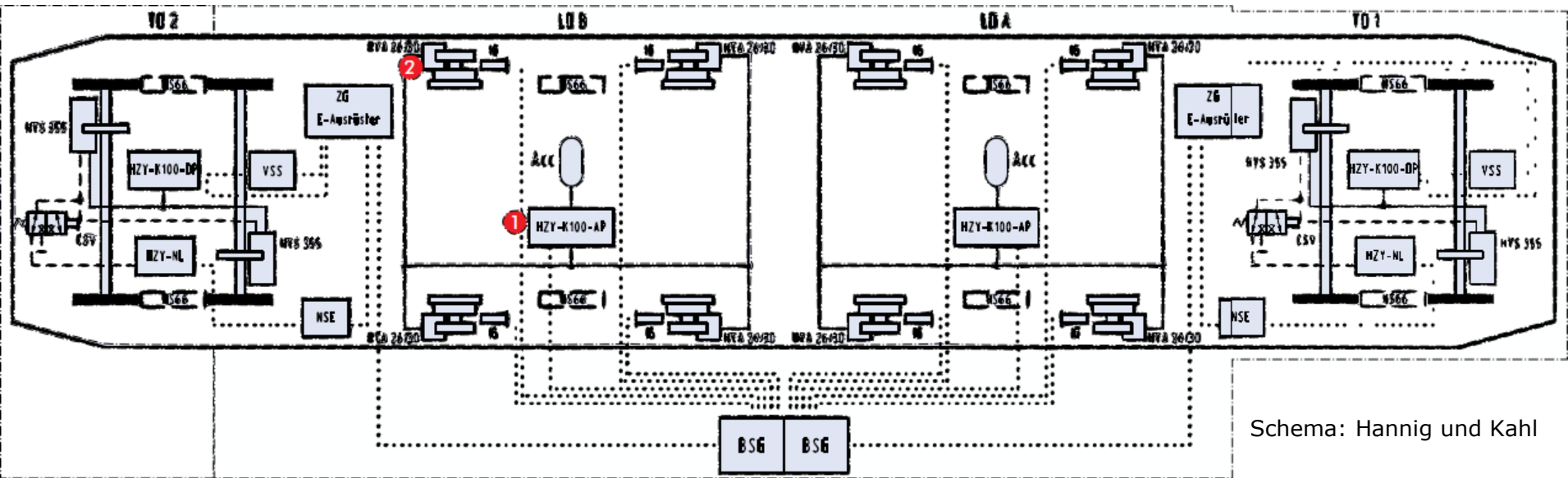

Schema: Hannig und Kahl

Elektro-Mechanische Bremsen

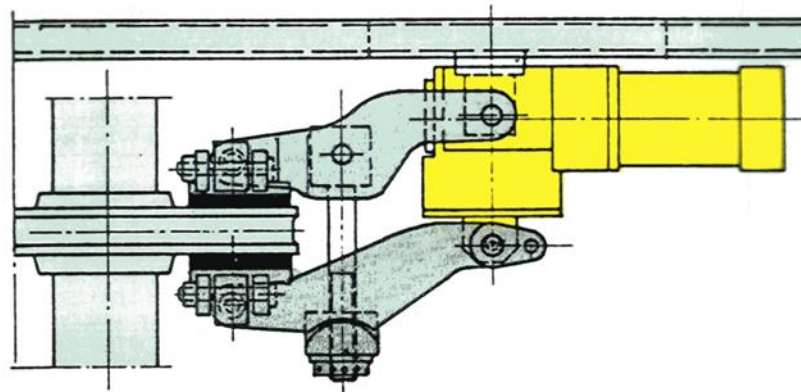
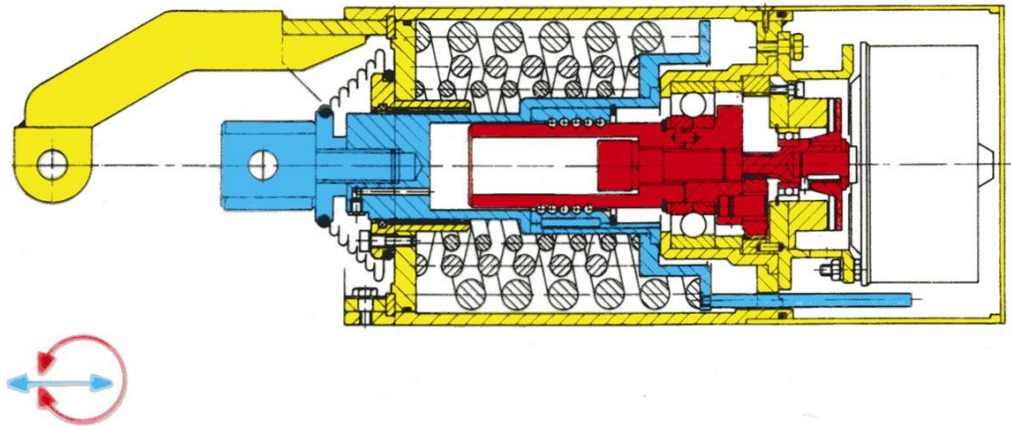

Beispiel EM-Bremse

(1) PASSIV

RACO-Federspeicherbremsgerät

GBM III

bestehend aus den Hauptgruppen:

- ① Federspeicher (Tellerfederpaket) mit Exzenterwelle und Schubzugstange
- ② Planetengetriebe
- ③ Gleichstrommotor mit Elektromagnetbremse

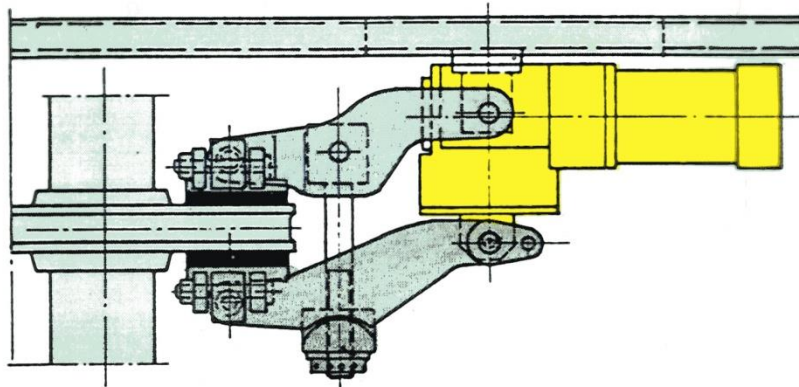
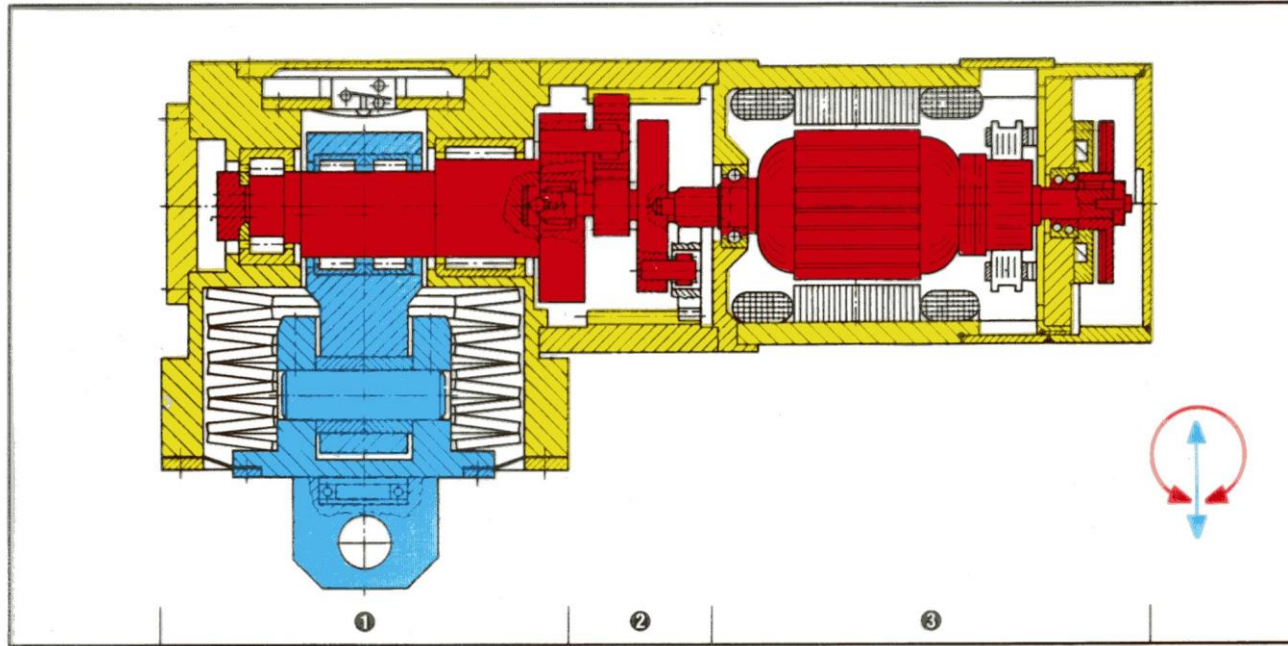

mögl. Einbausituation

Quelle: Raco

Beispiel EM-Bremse

(2) PASSIV

**RACO-Federspeicherbremsgerät
GBM VI**

bestehend aus den Hauptgruppen:

- ❶ Federspeicher (Mehrfachspiralfederpaket) mit Kugelgewindetrieb und Schubzugstange
- ❷ Planetengetriebe mit Elektromagnetbremse
- ❸ Gleichstrommotor

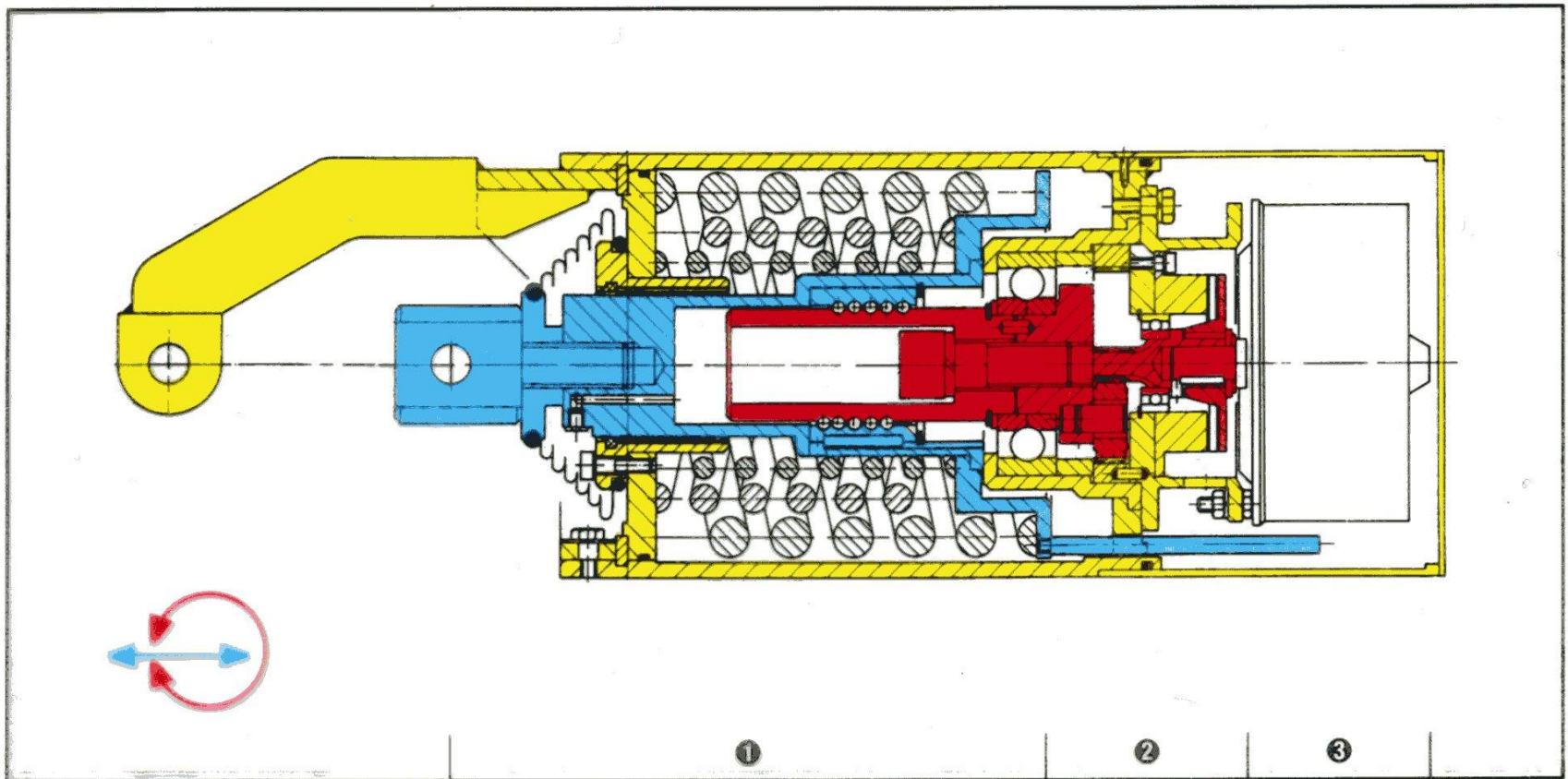

Quelle: Raco

EM-Bremse

ANWENDUNGEN, BEISPIELE



Calgary



San Diego



Wien



Zürich



Düsseldorf



Duisburg

Vergleich mechanischer Bremsen

Bewertetes Kriterium		Pneumatik	Hydraulik	Elektromechanik	Bemerkungen
Bauraum:	1. Erzeugung	-	o	o	
	2. Aufbereitung	-	o	+	
	3. Speicher	-	+	-	
	4. Aktuator	o	+	-	
Wirkungsgrad		-	o	+	
Dynamik		-	+	+	
Geräusentwicklung		-	o	o	
Kraftregelung		-	+	o	
Aufgelöste Bauweise möglich		+	+	-	
Verrohrung		-	o *	+	* Wenn nicht zentral
Anforderung an Montage		-	-	+	
Leckage		o	-	+	
Winterbetrieb		-	+	o	
Beanspruchung mechanischer Teile		+	+	-	
Kosten		120%	100%	120%	

nach Kipp in: ZEV + DET Glas. Ann. 11/12 1995